

Soluciones antivibratorias. Aislamiento de vibraciones, choques y ruidos
Antivibration solutions. Acoustic and vibration isolation, shock protection
Solutions antivibratoires. Isolation des vibrations, chocs et bruits
Vibrationsdämpfende Lösungen. Lärminderung, Isolierung von Stößen und Erschütterungen

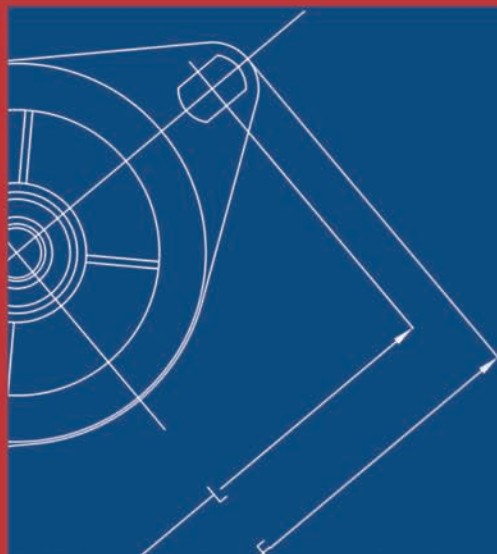

INTRODUCCIÓN / INTRODUCTION

LESOL, S.A es una empresa cuya actividad es la fabricación, comercialización y venta de material antivibratorio, así como la realización de estudios de ingeniería que de esta actividad puedan derivarse y que se concentran en el AISLAMIENTO DE VIBRACIONES, CHOQUES Y RUIDOS.

Desde 1984, aporta soluciones antivibratorias con el más alto nivel en productos, calidad y servicio.

LESOL, con sus sistemas antivibratorios, garantiza un correcto funcionamiento de los equipos, evitando la pérdida de potencia y reduciendo el número de averías. Aportando además, bienestar a las personas que trabajan en su entorno.

CALIDAD DE PRODUCCIÓN

LESOL, implicado en un sistema continuo de mejora, obtuvo y mantiene la certificación ISO 9001 en todos sus procesos de **"Fabricación y comercialización de material para el control de ruido, vibración y choques"**

LESOL dispone de la más alta tecnología en medios de desarrollo y control, lo que permite ofrecer a sus clientes unos productos y servicios de primera calidad.

*Copyright by Lesol 2013 - 2nd Edition.
LESOL se reserva el derecho a modificar los datos sin preaviso.
Las informaciones y fotos son indicativas y no tienen carácter contractual.*

LESOL S.A. manufactures and commercializes anti-vibration elements. Our engineering department realizes customized studies to **PREVENT FROM VIBRATION SHOCK AND NOISE.**

Since 1984, LESOL solves vibration problems ensuring high quality in production processes and customer service.

Antivibration systems guarantee a correct running of the machines and avoid loss of performance and prevent mechanical breakdown. In addition they contribute to the good health of the people working around.

PRODUCTION QUALITY

LESOL aspires to a continuous improvement of the production processes, according to the ISO 9001 Certificate.

LESOL disposes of the most updated and computer assisted technology for development and first quality services and products.

*Copyright by Lesol 2013 - 2nd Edition.
LESOL reserves the right to change design and specification of our products, without prior notification.
The informations and pictures are indicative and not contractual.*

LESOL, produit, distribue et vend du matériel antivibratoire. LESOL, S.A. réalise pour ses clients des études antivibratoires et préconise l'utilisation des silentblocks les plus adéquats pour L'ISOLATION DES VIBRATIONS, CHOCS ET BRUITS.

LESOL, fournit depuis 1984 des solutions antivibratoires du plus haut niveau, par rapport à ses produits, sa qualité et son service.

LESOL, avec ses systèmes antivibratoires, garantit le bon fonctionnement des équipements, évitant la perte de puissance et réduisant les pannes. Elle favorise en plus, le bien-être des personnes travaillant autour.

QUALITE DE PRODUCTION

LESOL, impliquée dans un système d'amélioration continue, a obtenu et maintient la Certification ISO 9001 pour tous les procès de « *Fabrication et commercialisation du matériel pour le contrôle du bruit, de la vibration et des chocs* »

LESOL, possède la plus haute technologie en moyens de développement et contrôle, ce qui permet d'offrir aux clients des produits et services de première qualité.

*Copyright by Lesol 2013 - 2nd Edition.
LESOL se réserve le droit de modifier les informations sans préavis.
Les informations et photos sont indicatives et ne sauraient engager notre responsabilité.*

LESOL produit et vend des éléments pour l'amortissement des vibrations. Le département ingénierie réalise pour ses clients des études spécifiques d'applications pour l'ISOLATION VIBRATIONS, BRUIT, VIBRATIONS ET SECOUSSES.

Depuis 1984, LESOL résout les problèmes de vibrations avec une haute qualité dans le processus de production et la flexibilité dans le service à la clientèle.

Les amortisseurs de vibrations prolongent la durée de vie des machines, garantissent la fonctionnalité, empêchent la perte de puissance, les pannes et l'usure prématurée. Ils réduisent le bruit des machines, ce qui a un effet positif sur les personnes dans l'environnement.

PRODUKTIONSQUALITÄT

LESOL strebt nach ständiger Verbesserung der Produktionsprozesse gemäss Qualitätsnorm ISO 9001:2008.

Modernste, computergestützte Technologie dient der Entwicklung sowie der Qualitätskontrolle und optimiert Produktion und Kundenservice.

*Copyright by Lesol 2013 - 2nd Edition.
Änderungen ohne vorherige Ankündigung vorbehalten.
Alle technischen Angaben und Fotografien sind ohne Gewähr.*

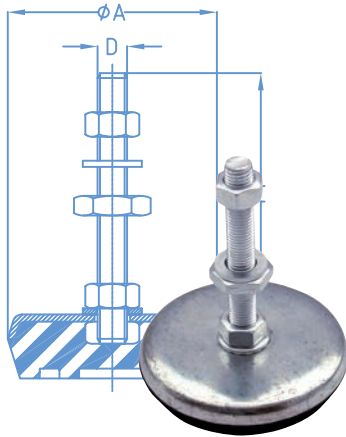

CAUCHO-METAL / RUBBER SILENT BLOCK
CAOUTCHOUC-METAL / GUMMI-METALL-
VERBINDUNGEN

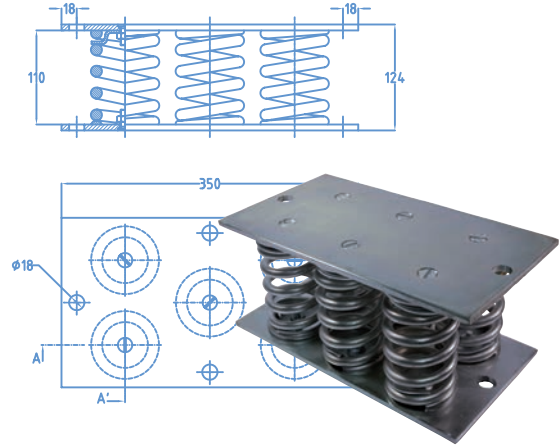

AISLANTES METÁLICOS / SPRING ISOLATOR
ISOLANTS METALIQUES / FEDERISOLATOREN

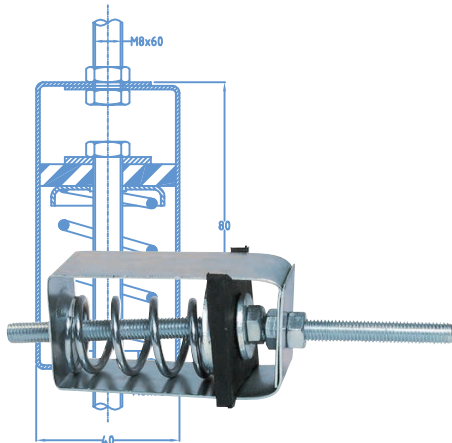



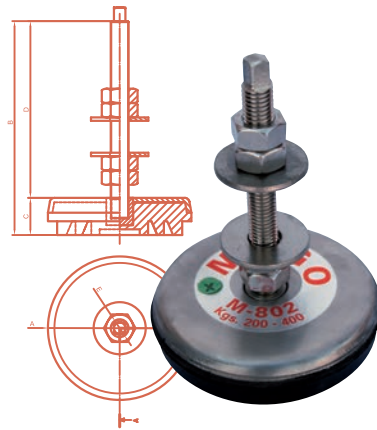







SUSTAINERS / HANGER / SUSPENTES
SCHALLSCHUTZ-DECKENELEMENTE



MAGO

<p>Pie de máquina / Machine base Pied machine / Maschinenfüsse</p>		<p>Pag. 11</p>
<p>R80T30 / R80T35 / AS</p>		<p>Pag. 12</p>
<p>A / Kit / Pack</p>		<p>Pag. 13</p>
<p>SR</p>		<p>Pag. 14</p>
<p>SR</p>		<p>Pag. 15</p>
<p>MR</p>		<p>Pag. 16</p>
<p>MR</p>		<p>Pag. 17</p>
<p>HR</p>		<p>Pag. 18</p>
<p>HR</p>		<p>Pag. 19</p>
<p>R</p>		<p>Pag. 20</p>
<p>R</p>		<p>Pag. 21</p>

TH		Pag. 22
TH		Pag. 23
TP		Pag. 24
SR-N / T / MR-N		Pag. 25
HR-N / R-N / TH-N		Pag. 26
SB53 / SH / SB / SBH		Pag. 27
B		Pag. 28
SCM		Pag. 29
SCM		Pag. 30
SCC		Pag. 31
LC		Pag. 32

SC		Pag. 33
Amortiguadores Antivibration Mounts Amortisseurs Schwingungsdämpfer		Pag. 34
Amortiguadores Antivibration Mounts Amortisseurs Schwingungsdämpfer		Pag. 35
Amortiguadores Antivibration Mounts Amortisseurs Schwingungsdämpfer		Pag. 36
RTK / OP		Pag. 37
RTP		Pag. 38
N T2 / M T2		Pag. 39
N (10 - 350 Kg.)		Pag. 40
2N / 3N / 4N (300 - 1400 Kg.)		Pag. 41
5N / 6N / 9N (750 - 3150 Kg.)		Pag. 42
M (25 - 550 Kg.)		Pag. 43

<p>2M / 3M / 4M (300 - 2200 Kg.)</p>		<p>Pag. 44</p>
<p>5M / 6M / 9M (750 - 4950 Kg.)</p>		<p>Pag. 45</p>
<p>M / 2M / 3M / 4M (500 - 3000 Kg.)</p>		<p>Pag. 46</p>
<p>5M / 6M / 9M (2500 - 6750 Kg.)</p>		<p>Pag. 47</p>
<p>4 ASMN / 6 ASMN</p>		<p>Pag. 48</p>
<p>HM / RM / HMB / HMBB</p>		<p>Pag. 49</p>
<p>Sustainer TM / TV</p>		<p>Pag. 50</p>
<p>Sustainer TVAD-DS / TVA TVAD10 / TVAR / TVAPL</p>		<p>Pag. 51</p>
<p>Sustainer TPA / TPB</p>		<p>Pag. 52</p>

M800 / M800 Inox / M700		Pag. 53
M600 (RÓTULA / ARTICULATED / ARTICULÉ / GELENKFÜß)		Pag. 54
M600 R / M600 T		Pag. 55
M940 / M950 / M		Pag. 56
M910 / M915/921		Pag. 57
M980 / M970		Pag. 58
M-400		Pag. 59
1000 Discobolo		Pag. 60
Stabren		Pag. 61
TP-M		Pag. 62
1100		Pag. 63

TIPOS DE CAUCHO / TYPES OF RUBBER / TYPES DE CAOUTCHOUC / GUMMIARTEN

COMMERCIAL NAME / NOMBRE COMERCIAL	BUTYL rubber	NATURAL RUBBER	PERBUNAN	NEOPRENE	SBR	SILICONE	APTK rubber
INT. DESIGNATION / NOMBRE INTER.	IIR	NR	NBR	CR	SBR	VMQ/SI	EPDM/EPM
Hardness available / Durezas disponibles	Shore 40-85	Shore 25-95	Shore 25-95	Shore 30-90	Shore 35-95	Shore 40-80	Shore 30-90
Resistance to temperatures / Rest. a temperaturas	-40°C to +130°C	-40°C to +80°C	-40°C to +140°C	-30°C to +120°C	-30°C to +110°C	-70°C up to +180°C	-40°C up to +150°C
Short-time peak temperature / Picos cortos de temperatura	+150°C	+100°C	up to +160°C	up to +150°C	up to +150°C	up to +225°C	up to +180°C
Tensile strength in kp / sp.cm / Rest. a la tracción	170(17)	250(25)	250(25)	250(25)	250(25)	80(8)	200(20)
Tensile elongation in% / Alargamiento a la tracción	400 to 800	800	500	450	450	250	450
PROPIEDADES / PROPERTIES - RESISTENCIAS							
Abrasion / Abrasión	good	good	very good	good	very good	moderate	good
Resistance to flex cracking / Rest. al agrietamiento por flexión	moderate	good	moderate	very good	good	bad	very good
Elongation-Tensile strength / Rest. a la tracción	good	excellent	good	good	good	bad	good
Flexibility / Flexibilidad	slight	excellent	good	good	good	good	good
Strength of structure / Rest. de la estructura	good	excellent	good	good	good	moderate	moderate
Resistance to light / Rest. a la luz	very good	bad	bad	very good	moderate	excellent	excellent
Resistance to oxidizing / Rest. a no oxidarse	very good	moderate	moderate	good	moderate	very good	excellent
Resistance to ozone / Rest. al ozono	very good	moderate	moderate	very good	moderate	excellent	excellent
Resistente to wear and tear / Rest. al desgaste	good	very good	very good	very good	very good	bad	good
Weathering effect / Rest. climatológica	very good	good	good	very good	good	excellent	excellent
RESISTENCIA A							
Lyes / Lejía	very good	good	good	very good	good	not suitable	excellent
Petrol / Petróleo	not suitable	not suitable	excellent	moderate	not suitable	not suitable	not suitable
Benzole / Benzol	not suitable	not suitable	bad	not suitable	not suitable	not suitable	not suitable
Foodstuffs / Productos alimenticios	suitable	suitable	suitable	suitable	suitable	excellently suitable	suitable
Solvents, aliphatic / Disolventes, alifáticos	not suitable	not suitable	very good	moderate	not suitable	not suitable	bad
Solvents, aromatic / Disolventes, aromáticos	not suitable	not suitable	conditional	moderate	not suitable	not suitable	not suitable
Solvents, halogene / Disolventes, halógeno	not suitable	not suitable	bad	bad	not suitable	not suitable	not suitable
Oils and greases / Aceites y grasas	not suitable	not suitable	excellent	good	not suitable	good	bad
Acids / Ácidos	very good	conditional	conditional	good	conditional	not suitable	very good
Water / Agua	good	good	good	very good	very good	good	very good

Not Suitable- No Apto
Bad- Malo

Suitable- Apto
Moderate- Moderado

Very Good- Muy Buena
Good- Buena

Excellent- Excelente
Excellently suitable- Muy Apto

PIE DE MÁQUINA / MACHINE BASE / PIED MACHINE / MASCHINENFÜSSE

	REF / ART.NR	DIMENSIONES / DIMENSIONS ABMESSUNGEN				COMPRESION / COMPRESSION DRUCKBELASTUNG	
		ØA	B	D	C	CARGA / LOAD CHARGE / LAST	FLECHA / DEFLECTION FLECHE / FEDERWEG
		mm.				kg.	mm.
S	000	40	23	M-08	55	60	3,5±0,5
	00	60	28	M-10	80	160	4,0±1,0
	0	70	32	M-12	100	300	4,5±1,0
	1	85	30	M-12	100	500	4,5±1,0
	2	100	40	M-14	110	600	6,0±1,0
	3	120	50	M-16	120	900	7,5±1,0
	4	140	50	M-16	120	1.200	8,0±1,0
	5	160	60	M-16	120	1.750	9,0±1,0
	6	180	70	M-24	136	2.500	11,0±1,5
	7	205	75	M-24	136	3.500	12,0±2,0
<i>DUREZA / HARDNESS / DURETE / HÄRTE 60 SHÖRE</i>							
S-B	00-B	60	18	M-10	80	200	2,0±0,5
	0-B	70	20	M-12	100	350	2,0±0,5
	1-B	85	25	M-12	100	600	2,2±0,5
	2-B	100	20	M-14	110	800	2,5±0,5
	3-B	120	25	M-16	120	1.100	2,5±0,5
	4-B	140	33	M-16	120	2.000	3,5±0,5
5-B	160	31	M-16	120	3.000	4,0±1,0	
<i>DUREZA / HARDNESS / DURETE / HÄRTE 70 SHÖRE</i>							
AS	AS4020-60SH	40	20	M-08	40	90	4,0±0,5
	AS5020-45SH	52	20	M-10	70	180	4,0±1,0
	AS6020-60SH	52	20	M-10	70	275	4,0±1,0
	AS6520-75SH	52	20	M-12	90	750	4,0±1,0
	AS7526-60SH	69	26	M-12	80	330	5,0±1,0
	AS8026-75SH	69	26	M-12	80	550	5,0±1,0

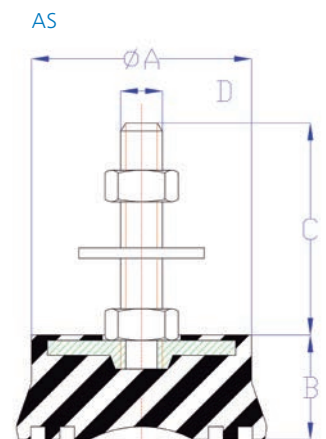
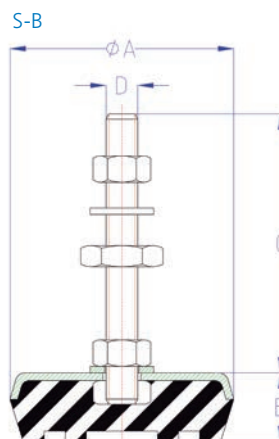
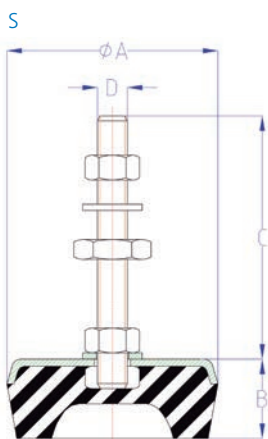

R80T30 / R80T35 / AS

R80T	REF / ART.NR	DIMENSIONES / DIMENSIONS ABMESSUNGEN					COMPRESION / COMPRESSION DRUCKBELASTUNG		
	TUBOØ	A	H	L	M	R	CARGA / LOAD CHARGE / LAST	FLECHA / DEFLECTION FLECHE / FEDERWEG	
	mm.					kg.	mm.		
	R80T30EPDM50	30	28	73	55	M-08	15,0	33	2,8±0,5
	R80T35EPDM50	35	28	70	56	M-08	17,5	26	2,2±0,5
<i>DUREZA / HARDNESS / DURETE / HÄRTE 50 SHÖRE</i>									
AS	REF / ART.NR	DIMENSIONES / DIMENSIONS ABMESSUNGEN				COMPRESION / COMPRESSION DRUCKBELASTUNG			
	ØA	B	D	C	CARGA / LOAD CHARGE / LAST	FLECHA / DEFLECTION FLECHE / FEDERWEG			
	mm.				kg.	mm.			
		AS-29	30	10	M-08	20	60	1,5±0,5	
		AS-39	40	15	M-10	25	60	2,0±0,5	
	AS-40	40	25	M-10	25	90	4,0±0,5		
	AS-55	55	30	M-10	50	150	4,5±0,5		
<i>DUREZA / HARDNESS / DURETE / HÄRTE 60 SHÖRE</i>									

AS29

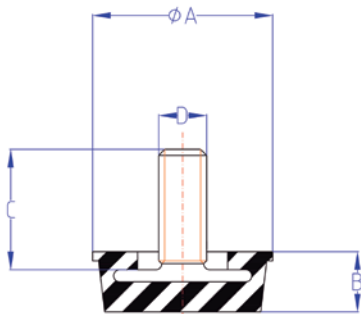

AS39

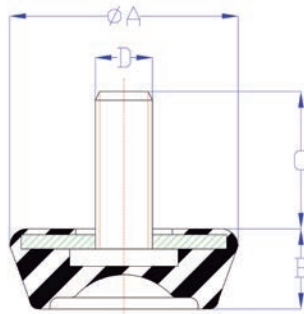

AS40-55

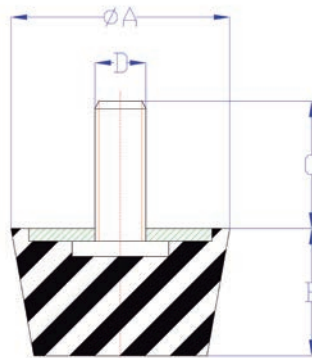

R80T

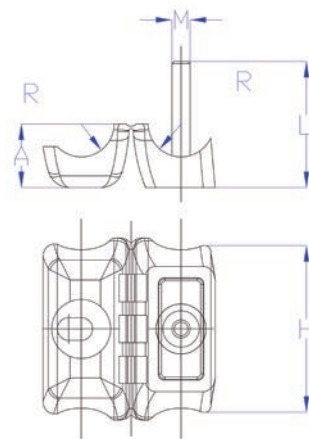

A / KIT / PACK

	REF / ART.NR	DIMENSIONES / DIMENSIONS ABMESSUNGEN					COMPRESION / COMPRESSION DRUCKBELASTUNG		
		Ø A	Ø A'	B	D	C	CARGA / LOAD CHARGE / LAST	FLECHA / DEFLECTION FLECHE / FEDERWEG	
		mm.					kg.	mm.	
	A35B	38	28	22	M-08	20	50	5,0±0,5	
	A35	38	28	22	M-08	20	100	5,0±0,5	
	A45B	45	32	30	M-08	20	65	6,0±1,0	
	A45	45	32	30	M-08	20	115	6,0±1,0	
	A35B PACK								
	A35 PACK								
	A45 PACK								
	AS4020BT								
	AS5020BT								
	AS6020BT								
	AS6520BT								
	AS7526BT								
R80T	REF / ART.NR	DIMENSIONES / DIMENSIONS ABMESSUNGEN					COMPRESION / COMPRESSION DRUCKBELASTUNG		
		TUBOØ	A	H	L	M	R	CARGA / LOAD CHARGE / LAST	FLECHA / DEFLECTION FLECHE / FEDERWEG
		mm.					kg.	mm.	
	R80T30PACK	30	28	73	55	M-08	15,0		
	R80T35PACK	35	28	70	56	M-08	17,5		

DUREZA / HARDNESS / DURETE / HÄRTE 50 SHÖRE

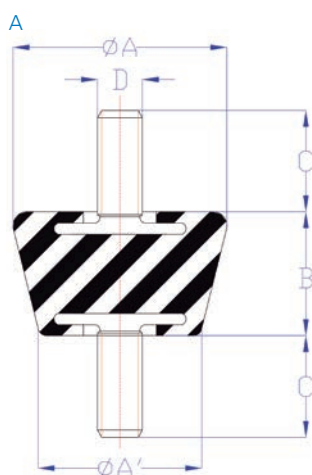

A35PACK



R80T30PACK



SR3015



AS4020BT

*Otras referencias y personalización de bolsas bajo consulta
*Other references and customizing if required
*D'autres références et personnalisation sous demande
*Kundenspezifische Packs auf Anfrage

SR

SR	REF / ART.NR		DIMENSIONES / DIMENSIONS ABMESSUNGEN				COMPRESION / COMPRESSION DRUCKBELASTUNG		CIZALLA / SHEAR CISAILLEMENT / SCHERKRAFT	
		Sh	ØA	B	D	C	CARGA / LOAD CHARGE / LAST	FLECHA / DEFLECTION FLECHE / FEDERWEG	CARGA / LOAD CHARGE / LAST	FLECHA / DEFLECTION FLECHE / FEDERWEG
	mm.						kg.	mm.	kg.	mm.
SR 1215	60	12	15	M-05	10	15	3,0±0,5	1,5	2,0±0,5	
SR 1610	60	16	10	M-05	12	20	1,5±0,5	2	2,0±0,5	
SR 1615	60	16	15	M-05	12	15	2,5±0,5	2	3,0±0,5	
SR 1620	60	16	20	M-05	12	15	3,5±0,5	2	4,0±0,5	
SR 1625	60	16	25	M-05	12	15	4,5±1,0	2	5,0±1,0	
SR 2008	60	20	08	M-06	15	45	1,0±0,3	4,5	1,5±0,3	
SR 2015	60	20	15	M-06	15	35	3,0±0,5	3,5	3,0±0,5	
SR 2020	60	20	20	M-06	15	25	4,0±1,0	2,5	4,0±0,5	
SR 2025	60	20	25	M-06	15	25	5,0±1,0	2,5	5,0±1,0	
SR 2030	60	20	30	M-06	15	25	6,0±1,0	2,5	6,0±1,0	
SR 2510	50	25	10	M-08	20	80	2,0±0,5	8	2,0±0,5	
SR 2515	50	25	15	M-08	20	60	3,0±0,5	8	3,0±0,5	
SR 2520	50	25	20	M-08	20	45	4,0±0,5	8	4,0±0,5	
SR 2525	50	25	25	M-08	20	40	5,0±1,0	6	5,0±1,0	
SR 2530	50	25	30	M-08	20	40	6,0±1,0	5	6,0±1,0	
SR 2540	50	25	40	M-08	20	40	8,0±1,0	5	8,0±1,0	
SR 2822	50	28	22	M-08	20	60	5,0±1,0	11	5,0±1,0	
SR 3010	50	30	10	M-08	20	80	2,0±0,5	11	2,0±0,5	
SR 3015	50	30	15	M-08	20	80	3,0±0,5	11	3,0±0,5	
SR 3020	50	30	20	M-08	20	80	4,0±0,5	11	4,0±0,5	
SR 3030	50	30	30	M-08	20	60	6,0±1,0	11	6,0±1,0	
SR 3040	50	30	40	M-08	20	60	8,0±1,0	11	8,0±1,0	

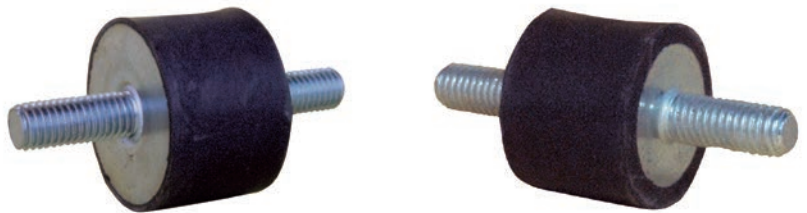
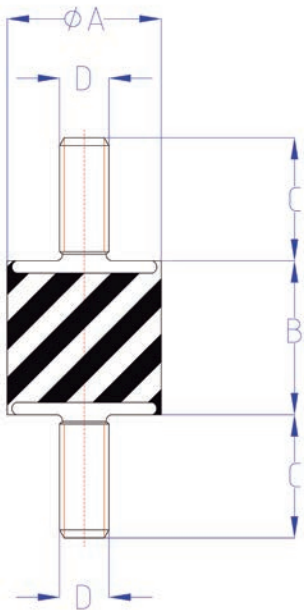

SR

SR	REF / ART.NR		DIMENSIONES / DIMENSIONS ABMESSUNGEN				COMPRESION / COMPRESSION DRUCKBELASTUNG		CIZALLA / SHEAR CISAILLEMENT / SCHERKRAFT	
		Sh	ØA	B	D	C	CARGA / LOAD CHARGE / LAST	FLECHA / DEFLECTION FLECHE / FEDERWEG	CARGA / LOAD CHARGE / LAST	FLECHA / DEFLECTION FLECHE / FEDERWEG
	mm.						kg.	mm.	kg.	mm.
SR 4020M8X20	50	40	20	M-08	20	160	4,0±0,5	20	4,0±0,5	
SR 4020	50	40	20	M-10	25	160	4,0±0,5	20	4,0±0,5	
SR 4028M8X30	50	40	28	M-08	30	100	5,5±1,0	16	5,5±1,0	
SR 4028M8X20	50	40	28	M-08	20	100	5,5±1,0	16	5,5±1,0	
SR 4028	50	40	28	M-10	25	100	5,5±1,0	16	5,5±1,0	
SR 4035	50	40	35	M-10	25	100	7,0±1,0	16	7,0±1,0	
SR 4040M8X20	50	40	40	M-08	20	100	8,0±1,0	16	8,0±1,0	
SR 4040	50	40	40	M-10	25	100	8,0±1,0	16	8,0±1,0	
SR 4045	50	40	45	M-10	25	100	9,0±1,0	16	9,0±1,0	
SR 5020	50	50	20	M-10	25	300	4,0±0,5	25	4,0±0,5	
SR 5025	50	50	25	M-10	25	175	5,0±1,0	25	5,0±1,0	
SR 5030	50	50	30	M-10	25	160	6,0±1,0	25	6,0±1,0	
SR 5035	50	50	35	M-10	25	160	7,0±1,0	25	7,0±1,0	
SR 5040	50	50	40	M-10	25	155	8,0±1,0	25	8,0±1,0	
SR 5045	50	50	45	M-10	25	150	9,0±1,0	25	9,0±1,0	
SR 5060	50	50	60	M-10	25	130	12,0±1,5	25	12,0±1,5	
SR 6025	50	60	25	M-10	25	400	5,0±1,0	35	5,0±1,0	
SR 6035	50	60	35	M-10	25	300	7,0±1,0	35	7,0±1,0	
SR 6045	50	60	45	M-10	25	250	9,0±1,0	35	9,0±1,0	
SR 6060	50	60	60	M-10	25	225	12,0±1,5	35	12,0±1,5	
SR 7035M10X25	50	70	35	M-10	25	450	7,0±1,0	55	7,0±1,0	
SR 7040M10X25	50	70	40	M-10	25	400	8,0±1,0	70	8,0±1,0	
SR 7050M10X25	50	70	50	M-10	25	300	10,0±1,0	35	10,0±1,0	
SR 7070M10X25	50	70	70	M-10	25	300	14,0±1,5	35	14,0±1,5	
SR 7035	50	70	35	M-12	33	450	7,0±1,0	55	7,0±1,0	
SR 7040	50	70	40	M-12	33	400	8,0±1,0	70	8,0±1,0	
SR 7050	50	70	50	M-12	33	300	10,0±1,0	35	10,0±1,0	
SR 7070	50	70	70	M-12	33	300	14,0±1,5	35	14,0±1,5	
SR 8030	50	80	30	M-14	35	950	6,0±1,0	100	6,0±1,0	
SR 8040	50	80	40	M-14	35	600	8,0±1,0	80	8,0±1,0	
SR 8055	50	80	55	M-14	35	500	11,0±1,5	70	11,0±1,5	
SR 9525	60	95	25	M-16	42	1800	5,0±1,0	80	5,0±1,0	
SR 9540	50	95	40	M-16	42	1000	8,0±1,0	140	8,0±1,0	
SR 15075	50	150	75	M-20	50	1800	15,0±2,0	275	15,0±2,0	

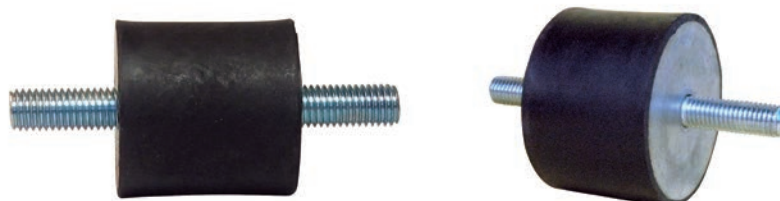
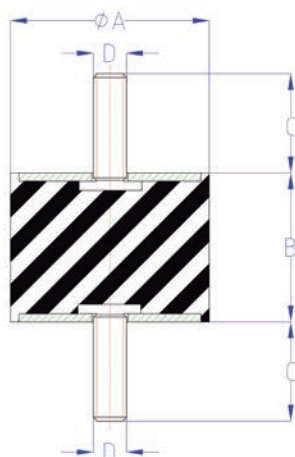

MR

MR	REF / ART.NR		DIMENSIONES / DIMENSIONS ABMESSUNGEN					COMPRESION / COMPRESSION DRUCKBELASTUNG		CIZALLA / SHEAR CISAILLEMENT / SCHERKRAFT	
		Sh	ØA	B	D	C	I	CARGA / LOAD CHARGE / LAST	FLECHA / DEFLECTION FLECHE / FEDERWEG	CARGA / LOAD CHARGE / LAST	FLECHA / DEFLECTION FLECHE / FEDERWEG
	mm.							kg.	mm.	kg.	mm.
	MR 1610	60	16	10	M-05	12	5	20	1,5±0,5	2	2,0±0,5
	MR 1615	60	16	15	M-05	12	5	15	2,5±0,5	2	3,0±0,5
	MR 1620	60	16	20	M-05	12	5	15	3,5±1,0	2	4,0±0,5
	MR 1625	60	16	25	M-05	12	5	15	4,5±1,0	2	5,0±0,5
	MR 2015	60	20	15	M-06	15	5	35	3,0±0,5	3,5	3,0±0,5
	MR 2020	60	20	20	M-06	15	5	30	4,0±1,0	2,5	4,0±0,5
	MR 2025	60	20	25	M-06	15	5	25	5,0±1,0	2,5	5,0±1,0
	MR 2030	60	20	30	M-06	15	5	25	6,0±1,0	2,5	6,0±1,0
	MR 2520	50	25	20	M-08	20	6	50	4,0±0,5	8	4,0±0,5
	MR 2525	50	25	25	M-08	20	6	45	5,0±1,0	6	5,0±1,0
	MR 2530	50	25	30	M-08	20	6	40	6,0±1,0	5	6,0±1,0
	MR 2540	50	25	40	M-08	20	6	40	8,0±1,0	5	8,0±1,0
	MR 2822	50	28	22	M-08	20	6	60	5,0±1,0	11	5,0±1,0
	MR 3015	50	30	15	M-08	20	6	80	3,0±0,5	11	3,0±0,5
	MR 3020	50	30	20	M-08	20	6	80	4,0±0,5	11	4,0±0,5
	MR 3030	50	30	30	M-08	20	6	60	6,0±1,0	11	6,0±1,0
	MR 3040	50	30	40	M-08	20	6	60	8,0±1,0	11	8,0±1,0

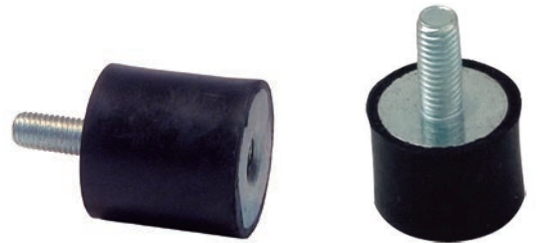
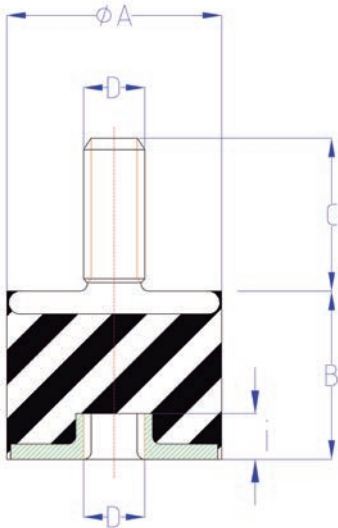

MR

REF / ART.NR	Sh	DIMENSIONES / DIMENSIONS ABMESSUNGEN					COMPRESION / COMPRESSION DRUCKBELASTUNG		CIZALLA / SHEAR CISAILLEMENT / SCHERKRAFT	
		ØA	B	D	C	I	CARGA / LOAD CHARGE / LAST	FLECHA / DEFLECTION FLECHE / FEDERWEG	CARGA / LOAD CHARGE / LAST	FLECHA / DEFLECTION FLECHE / FEDERWEG
		mm.					kg.	mm.	kg.	mm.
MR 4020M8X20	50	40	20	M-08	20	6	175	4,0±0,5	20	4,0±0,5
MR 4020	50	40	20	M-10	25	7	175	4,0±0,5	20	4,0±0,5
MR 4028M8X30	50	40	28	M-08	30	6	125	5,5±1,0	16	5,5±1,0
MR 4028M8X20	50	40	28	M-08	20	6	125	5,5±1,0	16	5,5±1,0
MR 4028	50	40	28	M-10	25	7	125	5,5±1,0	16	5,5±1,0
MR 4035	50	40	35	M-10	25	7	100	7,0±1,0	16	7,0±1,0
MR 4040M8X20	50	40	40	M-08	20	6	100	8,0±1,0	16	8,0±1,0
MR 4040	50	40	40	M-10	25	7	100	8,0±1,0	16	8,0±1,0
MR 4045	50	40	45	M-10	25	7	100	9,0±1,0	16	9,0±1,0
MR 5020	50	50	20	M-10	25	7	300	4,0±0,5	25	4,0±0,5
MR 5025	50	50	25	M-10	25	7	175	5,0±1,0	25	5,0±1,0
MR 5030	50	50	30	M-10	25	7	160	6,0±1,0	25	6,0±1,0
MR 5035	50	50	35	M-10	25	7	160	7,0±1,0	25	7,0±1,0
MR 5040	50	50	40	M-10	25	7	155	8,0±1,0	25	8,0±1,0
MR 5045	50	50	45	M-10	25	7	150	9,0±1,0	25	9,0±1,0
MR 5060	50	50	60	M-10	25	7	130	12,0±1,5	25	12,0±1,5
MR 6025	50	60	25	M-10	25	7	400	5,0±1,0	35	5,0±1,0
MR 6035	50	60	35	M-10	25	7	300	7,0±1,0	35	7,0±1,0
MR 6045	50	60	45	M-10	25	7	250	9,0±1,0	35	9,0±1,0
MR 6060	50	60	60	M-10	25	7	225	12,0±1,5	35	12,0±1,5
MR 7035M10X25	50	70	35	M-10	25	9	450	7,0±1,0	55	7,0±1,0
MR 7040M10X25	50	70	40	M-10	25	9	400	8,0±1,0	70	8,0±1,0
MR 7050M10X25	50	70	50	M-10	25	9	300	10,0±1,0	35	10,0±1,0
MR 7070M10X25	50	70	70	M-10	25	9	300	14,0±1,5	35	14,0±1,5
MR 7035	50	70	35	M-12	33	10	450	7,0±1,0	55	7,0±1,0
MR 7040	50	70	40	M-12	33	10	400	8,0±1,0	70	8,0±1,0
MR 7050	50	70	50	M-12	33	10	300	10,0±1,0	35	10,0±1,0
MR 7070	50	70	70	M-12	33	10	300	14,0±1,5	35	14,0±1,5
MR 7525	50	75	25	M-12	33	10	650	5,0±1,0	80	5,0±1,0
MR 7555	50	75	55	M-12	33	10	400	11,0±1,0	75	11,0±1,5
MR 8030	50	80	30	M-14	35	11	950	6,0±1,0	100	6,0±1,0
MR 8040	50	80	40	M-14	35	11	600	8,0±1,0	80	8,0±1,0
MR 8055	50	80	55	M-14	35	11	500	11,0±1,5	70	11,0±1,5
MR 9540	50	95	40	M-16	42	14	1000	8,0±1,0	140	8,0±1,0
MR 15075	50	150	75	M-20	50	20	1800	15,0±2,0	275	15,0±2,0

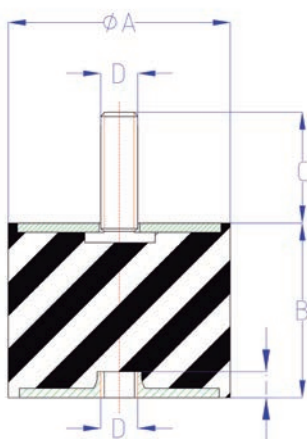

HR

HR	REF / ART.NR		DIMENSIONES / DIMENSIONS ABMESSUNGEN				COMPRESION / COMPRESSION DRUCKBELASTUNG		CIZALLA / SHEAR CISAILLEMENT / SCHERKRAFT	
		Sh	ØA	B	D	l	CARGA / LOAD CHARGE / LAST	FLECHA / DEFLECTION FLECHE / FEDERWEG	CARGA / LOAD CHARGE / LAST	FLECHA / DEFLECTION FLECHE / FEDERWEG
	mm.						kg.	mm.	kg.	mm.
	HR 1615	60	16	15	M-05	5	15	2,5±0,5	2	2,0±0,5
	HR 1620	60	16	20	M-05	5	15	3,5±0,5	2	4,0±0,5
	HR 1625	60	16	25	M-05	5	15	4,5±1,0	2	5,0±1,0
	HR 2015	60	20	15	M-06	5	40	2,0±0,5	3,5	3,0±0,5
	HR 2020	60	20	20	M-06	5	30	4,0±1,0	2,5	4,0±0,5
	HR 2025	60	20	25	M-06	5	30	5,0±1,0	2,5	5,0±1,0
	HR 2030	60	20	30	M-06	5	25	6,0±1,0	2,5	6,0±1,0
	HR 2520	50	25	20	M-08	6	50	4,0±0,5	8	4,0±0,5
	HR 2525	50	25	25	M-08	6	45	5,0±1,0	6	5,0±1,0
	HR 2530	50	25	30	M-08	6	40	6,0±1,0	5	6,0±1,0
	HR 2540	50	25	40	M-08	6	40	8,0±1,0	5	8,0±1,0
	HR 2822	50	28	22	M-08	6	60	4,5±1,0	11	5,0±1,0
	HR 3020	50	30	20	M-08	6	80	4,0±0,5	11	4,0±0,5
	HR 3030	50	30	30	M-08	6	60	6,0±1,0	11	6,0±1,0
	HR 3330	60	30	30	M-08	6	80	6,0±1,0	16	6,0±1,0
	HR 3040	50	30	40	M-08	6	60	8,0±1,0	11	8,0±1,0

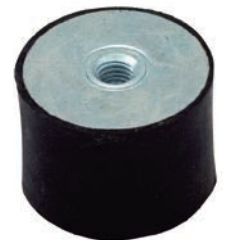
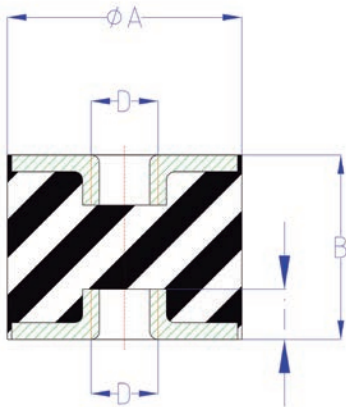

HR

REF / ART.NR	DIMENSIONES / DIMENSIONS ABMESSUNGEN					COMPRESION / COMPRESSION DRUCKBELASTUNG		CIZALLA / SHEAR CISAILLEMENT / SCHERKRAFT	
	Sh	ØA	B	D	I	CARGA / LOAD CHARGE / LAST	FLECHA / DEFLECTION FLECHE / FEDERWEG	CARGA / LOAD CHARGE / LAST	FLECHA / DEFLECTION FLECHE / FEDERWEG
		mm.					kg.	mm.	kg.
HR 4020	50	40	20	M-10	7	175	4,0±0,5	20	4,0±0,5
HR 4028M8	50	40	28	M-08	6	125	5,5±1,0	16	5,5±1,0
HR 4028	50	40	28	M-10	7	125	5,5±1,0	16	5,5±1,0
HR 3430	60	40	30	M-08	6	200	6,0±1,0	40	6,0±1,0
HR 4035	50	40	35	M-10	7	100	7,0±1,0	16	7,0±1,0
HR 4040M8	50	40	40	M-08	6	100	8,0±1,0	16	8,0±1,0
HR 4040	50	40	40	M-10	7	100	8,0±1,0	16	8,0±1,0
HR 4045M8	50	40	45	M-08	6	100	9,0±1,0	16	9,0±1,0
HR 4045	50	40	45	M-10	7	100	9,0±1,0	16	9,0±1,0
HR 5020	50	50	20	M-10	7	300	4,0±0,5	25	4,0±0,5
HR 5025	50	50	25	M-10	7	175	5,0±1,0	25	5,0±1,0
HR 5030	50	50	30	M-10	7	160	6,0±1,0	25	6,0±1,0
HR 5035	50	50	35	M-10	7	160	7,0±1,0	25	7,0±1,0
HR 5040	50	50	40	M-10	7	155	8,0±1,0	25	8,0±1,0
HR 5045	50	50	45	M-10	7	150	9,0±1,0	25	9,0±1,0
HR 5060	50	50	60	M-10	7	130	12,0±1,5	25	12,0±1,5
HR 6025	50	60	25	M-10	7	400	5,0±1,0	35	5,0±1,0
HR 6035	50	60	35	M-10	7	300	7,0±1,0	35	7,0±1,0
HR 6045	50	60	45	M-10	7	250	9,0±1,0	35	9,0±1,0
HR 6060	50	60	60	M-10	7	225	12,0±1,5	35	11,0±1,5
HR 7035M10	50	70	35	M-10	9	450	7,0±1,0	55	7,0±1,0
HR 7040M10	50	70	40	M-10	9	400	8,0±1,0	70	8,0±1,0
HR 7050M10	50	70	50	M-10	9	300	10,0±1,0	35	10,0±1,0
HR 7070M10	50	70	70	M-10	9	300	14,0±1,5	35	14,0±1,5
HR 7035	50	70	35	M-12	10	450	7,0±1,0	55	7,0±1,0
HR 7040	50	70	40	M-12	10	400	8,0±1,0	70	8,0±1,0
HR 7050	50	70	50	M-12	10	300	10,0±1,0	35	10,0±1,0
HR 7070	50	70	70	M-12	10	300	14,0±1,5	35	14,0±1,5
HR 8030	50	80	30	M-14	11	950	6,0±1,0	100	6,0±1,0
HR 8040	50	80	40	M-14	11	600	8,0±1,0	80	8,0±1,0
HR 8055	50	80	55	M-14	11	500	11,0±1,5	70	11,0±1,5
HR 9540	50	95	40	M-16	14	1000	8,0±1,0	140	8,0±1,0
HR 102D45	45	102	55	M-16	14	500	11,0±1,5	100	11,0±1,5
HR 102D60	60	102	55	M-16	14	1000	11,0±1,5	200	11,0±1,5
HR 102D75	75	102	55	M-16	14	2500	11,0±1,5	350	11,0±1,5
HR 15075	50	150	75	M-20	20	1800	15,0±2,0	275	15,0±2,0

HR

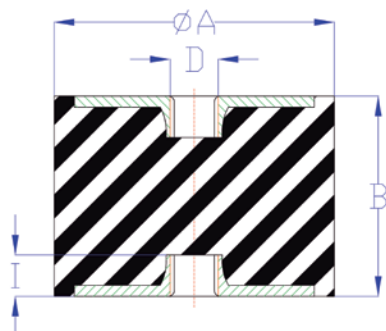

HR102

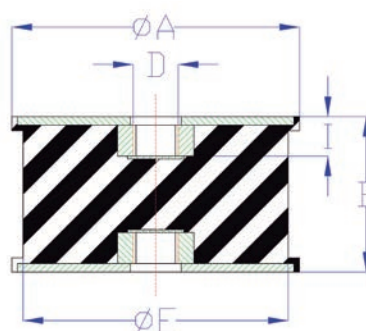

R

R	REF / ART.NR		DIMENSIONES / DIMENSIONS ABMESSUNGEN				COMPRESION / COMPRESSION DRUCKBELASTUNG	
		Sh	ØA	B	D	C	CARGA / LOAD CHARGE / LAST	FLECHA / DEFLECTION FLECHE / FEDERWEG
	mm.						kg.	mm.
	R 1215	60	12	15	M-05	10	15	3,0±0,5
	R 1610	60	16	10	M-05	12	20	1,5±0,5
	R 1615	60	16	15	M-05	12	15	2,5±0,5
	R 1620	60	16	20	M-05	12	15	3,5±0,5
	R 1625	60	16	25	M-05	12	15	4,5±1,0
	R 2008	60	20	08	M-06	15	45	1,6±0,5
	R 2015	60	20	15	M-06	15	35	3,0±0,5
	R 2020	60	20	20	M-06	15	25	4,0±1,0
	R 2025	60	20	25	M-06	15	25	5,0±1,0
	R 2030	60	20	30	M-06	15	25	6,0±1,0
	R 2510	50	25	10	M-08	20	50	2,0±0,5
	R 2515	50	25	15	M-08	20	40	3,0±0,5
	R 2520	50	25	20	M-08	20	40	4,0±0,5
	R 2525	50	25	25	M-08	20	40	5,0±1,0
	R 2530	50	25	30	M-08	20	40	6,0±1,0
	R 2540	50	25	40	M-08	20	40	8,0±1,0
	R 2822	50	28	22	M-08	20	60	5,0±1,0
	R 3010	50	30	10	M-08	20	80	2,0±0,5
	R 3015	50	30	15	M-08	20	80	3,0±0,5
	R 3020	50	30	20	M-08	20	80	4,0±0,5
	R 3030	50	30	30	M-08	20	60	6,0±1,0
	R 3040	50	30	40	M-08	20	60	8,0±1,0

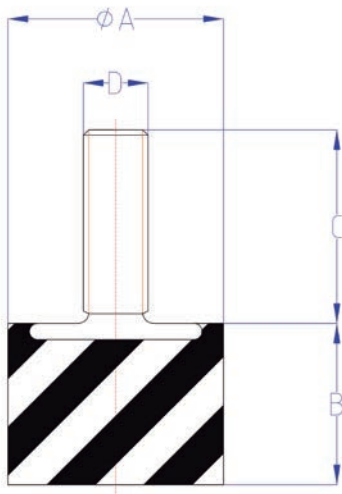

R

REF / ART.NR	DIMENSIONES / DIMENSIONS ABMESSUNGEN					COMPRESION / COMPRESSION DRUCKBELASTUNG	
	Sh	ØA	B	D	C	CARGA / LOAD CHARGE / LAST	FLECHA / DEFLECTION FLECHE / FEDERWEG
	mm.					kg.	mm.
R 4020M8X20	50	40	20	M-08	20	140	4,0±0,5
R 4020	50	40	20	M-10	25	140	4,0±0,5
R 4028M8X20	50	40	28	M-08	20	100	5,5±1,0
R 4028	50	40	28	M-10	25	100	5,5±1,0
R 4035	50	40	35	M-10	25	100	7,0±1,0
R 4040M8X20	50	40	40	M-08	20	100	8,0±1,0
R 4040	50	40	40	M-10	25	100	8,0±1,0
R 4045	50	40	45	M-10	25	90	9,0±1,0
R 5020	50	50	20	M-10	25	300	4,0±0,5
R 5025	50	50	25	M-10	25	175	5,0±1,0
R 5030	50	50	30	M-10	25	160	6,0±1,0
R 5035	50	50	35	M-10	25	160	7,0±1,0
R 5040	50	50	40	M-10	25	155	8,0±1,0
R 5045	50	50	45	M-10	25	150	9,0±1,0
R 5060	50	50	60	M-10	25	130	12,0±1,5
R 6025	50	60	25	M-10	25	400	5,0±1,0
R 6035	50	60	35	M-10	25	300	7,0±1,0
R 6045	50	60	45	M-10	25	250	9,0±1,0
R 6060	50	60	60	M-10	25	225	12,0±1,5
R 7035M10X25	50	70	35	M-10	25	450	7,0±1,0
R 7040M10X25	50	70	40	M-10	25	400	8,0±1,0
R 7050M10X25	50	70	50	M-10	25	300	10,0±1,0
R 7070M10X25	50	70	70	M-10	25	300	14,0±1,5
R 7035	50	70	35	M-12	33	450	7,0±1,0
R 7040	50	70	40	M-12	33	400	8,0±1,0
R 7050	50	70	50	M-12	33	300	10,0±1,0
R 7070	50	70	70	M-12	33	300	14,0±1,5
R 7525	50	75	25	M-12	33	650	5,0±1,0
R 8030	50	80	30	M-14	35	950	6,0±1,0
R 8040	50	80	40	M-14	35	600	8,0±1,0
R 8055	50	80	55	M-14	35	500	11,0±1,5
R 9525	60	95	25	M-16	42	1800	5,0±1,0
R 9540	50	95	40	M-16	42	1000	8,0±1,0

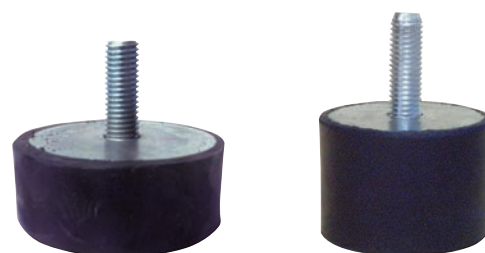
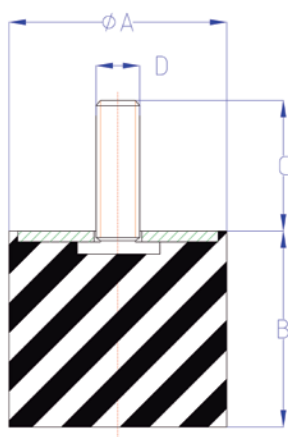

TH

TH	REF / ART.NR		DIMENSIONES / DIMENSIONS ABMESSUNGEN				COMPRESION / COMPRESSION DRUCKBELASTUNG	
		Sh	ØA	B	D	i	CARGA / LOAD CHARGE / LAST	FLECHA / DEFLECTION FLECHE / FEDERWEG
	mm.						kg.	mm.
TH 1610	60	16	10	M-05	5	20	1,5±0,5	
TH 1615	60	16	15	M-05	5	15	2,5±0,5	
TH 1620	60	16	20	M-05	5	15	3,5±1,0	
TH 1625	60	16	25	M-05	5	15	4,5±1,0	
TH 2008	60	20	08	M-06	5	45	1,6±0,5	
TH 2015	60	20	15	M-06	5	35	3,0±0,5	
TH 2020	60	20	20	M-06	5	25	4,0±1,0	
TH 2025	60	20	25	M-06	5	25	5,0±1,0	
TH 2030	60	20	30	M-06	5	25	6,0±1,0	
TH 2510	50	25	10	M-08	6	50	2,0±0,5	
TH 2515	50	25	15	M-08	6	40	3,0±0,5	
TH 2520	50	25	20	M-08	6	40	4,0±0,5	
TH 2525	50	25	25	M-08	6	40	5,0±1,0	
TH 2530	50	25	30	M-08	6	40	6,0±1,0	
TH 2540	50	25	40	M-08	6	40	8,0±1,0	
TH 2822	50	28	22	M-08	6	60	5,0±1,0	
TH 3010	50	30	10	M-08	6	80	2,0±0,5	
TH 3015	50	30	15	M-08	6	80	3,0±0,5	
TH 3020	50	30	20	M-08	6	80	4,0±0,5	
TH 3030	50	30	30	M-08	6	60	6,0±1,0	
TH 3040	50	30	40	M-08	6	60	8,0±1,0	

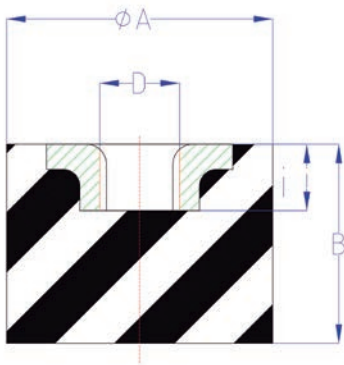

TH

TH	REF / ART.NR		DIMENSIONES / DIMENSIONS ABMESSUNGEN				COMPRESION / COMPRESSION DRUCKBELASTUNG	
		Sh	ØA	B	D	i	CARGA / LOAD CHARGE / LAST	FLECHA / DEFLECTION FLECHE / FEDERWEG
	mm.						kg.	mm.
	TH 4020M8	50	40	20	M-08	6	140	4,0±0,5
	TH 4020	50	40	20	M-10	7	140	4,0±0,5
	TH 4028M8	50	40	28	M-08	6	100	5,5±1,0
	TH 4028	50	40	28	M-10	7	100	5,5±1,0
	TH 4035	50	40	35	M-10	7	100	7,0±1,0
	TH 4040M8	50	40	40	M-08	6	100	8,0±1,0
	TH 4040	50	40	40	M-10	7	100	8,0±1,0
	TH 4045	50	40	45	M-10	7	90	9,0±1,0
	TH 5020	50	50	20	M-10	7	300	4,0±0,5
	TH 5025	50	50	25	M-10	7	175	5,0±1,0
	TH 5030	50	50	30	M-10	7	160	6,0±1,0
	TH 5035	50	50	35	M-10	7	160	7,0±1,0
	TH 5040	50	50	40	M-10	7	155	8,0±1,0
	TH 5045	50	50	45	M-10	7	150	9,0±1,0
	TH 5060	50	50	60	M-10	7	130	12,0±1,5
	TH 6025	50	60	25	M-10	7	400	5,0±1,0
	TH 6035	50	60	35	M-10	7	300	7,0±1,0
	TH 6045	50	60	45	M-10	7	250	9,0±1,0
	TH 6060	50	60	60	M-10	7	225	12,0±1,5
	TH 7035M10	50	70	35	M-10	9	450	7,0±1,0
	TH 7040M10	50	70	40	M-10	9	400	8,0±1,0
	TH 7050M10	50	70	50	M-10	9	300	10,0±1,0
	TH 7070M10	50	70	70	M-10	9	300	14,0±1,5
	TH 7035	50	70	35	M-12	10	450	7,0±1,0
	TH 7040	50	70	40	M-12	10	400	8,0±1,0
	TH 7050	50	70	50	M-12	10	300	10,0±1,0
	TH 7070	50	70	70	M-12	10	300	14,0±1,5
	TH 8030	50	80	30	M-14	11	950	6,0±1,0
	TH 8040	50	80	40	M-14	11	600	8,0±1,0
	TH 8055	50	80	55	M-14	11	500	11,0±1,5
	TH 9525	60	95	25	M-16	14	1800	5,0±1,0
	TH 9540	50	95	40	M-16	14	1000	8,0±1,0

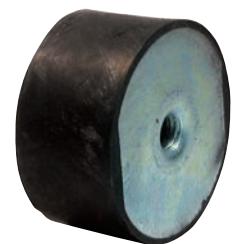
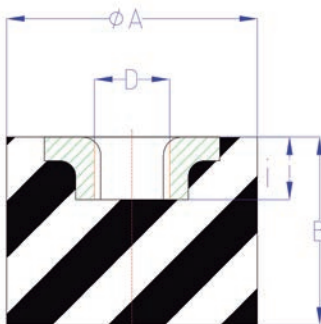

TP

	REF / ART.NR	DIMENSIONES / DIMENSIONS ABMESSUNGEN				COMPRESION / COMPRESSION DRUCKBELASTUNG		CHOQUE / SHOCK CHOC / STOSS		
		Sh	ØA	B	D	C	CARGA / LOAD CHARGE / LAST	FLECHA / DEFLECTION FLECHE / FEDERWEG	CARGA / LOAD CHARGE / LAST	FLECHA / DEFLECTION FLECHE / FEDERWEG
		mm.				kg.	mm	kg.	mm.	
TP-1	TP 25	60	25	20	M-08	20	40	4,0±0,5	100	8,0±2,0
	TP 30	60	30	30	M-06	15	50	6,0±1,0	140	12,0±2,0
	TP 30M8X20	60	30	30	M-08	20	50	6,0±1,0	140	12,0±2,0
	TP 5050M8X20	60	50	50	M-08	20	90	10,0±1,5	335	20,0±3,0
	TP 5050M10	60	50	50	M-10	25	90	10,0±1,5	335	20,0±3,0
	TP 5058M8X20	60	50	58	M-08	20	90	12,0±2,0	370	23,0±3,0
	TP 5058M10	60	50	58	M-10	25	90	12,0±2,0	370	23,0±3,0
	TP 5065M8X20	60	50	65	M-08	20	90	13,0±2,0	370	26,0±4,0
	TP 5065M10	60	50	65	M-10	25	90	13,0±2,0	370	26,0±4,0
	TP70	60	70	60	M-12	33	160	12,0±2,0	550	24,0±3,0
TP95	60	95	80	M-16	42	350	16,0±2,0	1100	32,0±4,0	
TP-2	TP85	60	84	53	M-12	33	375	11,0±2,0	1250	21,0±2,5
	TP96	60	95	47	M-16	42	675	9,0±1,0	1600	19,0±2,0
	TP120	75	120	75	M-16	42	2000	15,0±2,0	4500	30,0±4,0
	TP220	60	220	136	M-24	80	3800	27,0±3,0	10000	54,0±6,0

TP-1

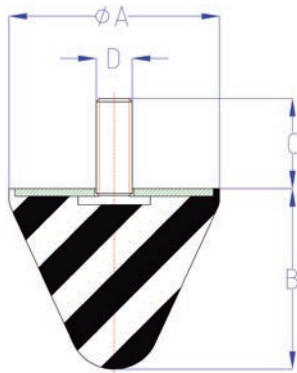

TP-2

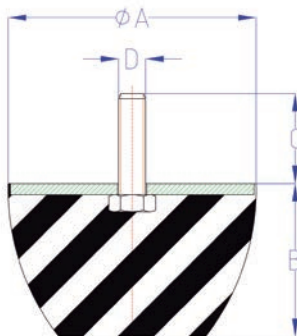

DIABOLOS

	REF / ART.NR	DIMENSIONES / DIMENSIONS ABMESSUNGEN						COMPRESION / COMPRESSION DRUCKBELASTUNG		CIZALLA / SHEAR CISAILLEMENT / SCHERKRAFT		
		Sh	ØA	B	ØE	D	C	I	CARGA / LOAD CHARGE / LAST	FLECHA / DEFLECTION FLECHE / FEDERWEG	CARGA / LOAD CHARGE / LAST	FLECHA / DEFLECTION FLECHE / FEDERWEG
	mm.						kg.	mm.	kg.	mm.		
SR-N	SR 00-N	60	20	19	13	M-06	15		12	4,0±1,0	2	4,0±0,5
	SR 0NM8	50	40	28	20	M-08	30		40	5,5±1,0	7	5,5±1,0
	SR 0N	50	40	28	20	M-10	25		40	5,5±1,0	7	5,5±1,0
	SR 1N	50	57	44	24	M-08	20		70	8,5±1,0	10	8,5±1,0
	SR 2N	50	57	44	38	M-08	20		130	8,5±1,0	25	8,5±1,0
	SR 4N	50	60	60	48	M-10	25		150	10,0±1,0	20	12,0±1,5
	SR 5N	50	80	70	68	M-14	35		350	14,0±1,5	65	14,0±1,5
	SR 6N	50	95	76	76	M-16	42		450	15,0±2,0	75	15,0±2,0
	SR 7N	50	108	75	97	M-16	42		600	15,0±2,0	140	15,0±2,0
SR 8N	50	130	85	117	M-16	42		900	17,0±2,0	185	17,0±2,0	
T	3376	60	30	25	24	M-08	20		60	5,0±1,0	8	5,0±1,0
	3230	60	60	36	37	M-10	25		250	7,0±1,0	40	7,0±1,0
	3231	60	60	43	38	M-10	25		250	9,0±1,0	30	9,0±1,0
MR-N	MR 0NM8	50	40	28	20	M-08	30	6	40	5,5±1,0	7	5,5±1,0
	MR 0N	50	40	28	20	M-10	25	7	40	5,5±1,0	7	5,5±1,0
	MR 2N	50	57	44	38	M-08	25	6	130	8,5±1,0	25	8,5±1,0
	MR 4N	50	60	60	48	M-10	25	7	150	10,0±1,0	20	10,0±1,0
	MR 5N	50	80	70	68	M-14	35	11	350	14,0±1,5	65	14,0±1,5
	MR 6N	50	95	76	76	M-16	42	14	450	15,0±2,0	75	15,0±2,0
	MR 7N	50	108	75	97	M-16	42	14	600	15,0±2,0	140	15,0±2,0
	MR 8N	50	130	85	117	M-16	42	14	900	17,0±2,0	185	17,0±2,0

SR-N

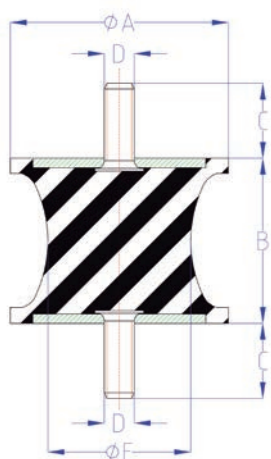

T

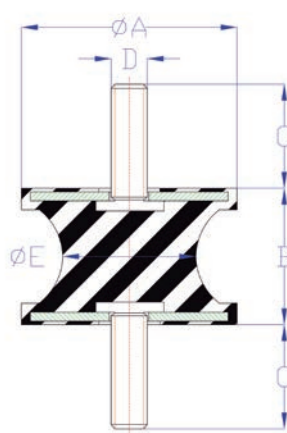

MR-N

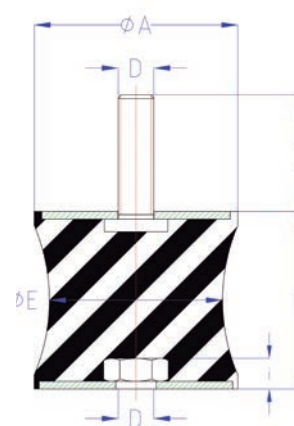

DIABOLOS

	REF / ART.NR		DIMENSIONES / DIMENSIONS ABMESSUNGEN					COMPRESION / COMPRESSION DRUCKBELASTUNG		CIZALLA / SHEAR CISAILLEMENT / SCHERKRAFT		
		Sh	ØA	B	ØE	D	C	I	CARGA / LOAD CHARGE / LAST	FLECHA / DEFLECTION FLECHE / FEDERWEG	CARGA / LOAD CHARGE / LAST	FLECHA / DEFLECTION FLECHE / FEDERWEG
	mm.								kg.	mm.	kg.	mm.
HR-N	HRONM8	50	40	28	20	M-08		6	40	5,5±1,0	7	5,5±1,0
	HR 0-N	50	40	28	20	M-10		7	40	5,5±1,0	7	5,5±1,0
	HR 2-N	50	57	44	38	M-08		6	130	8,5±1,0	25	8,5±1,0
	HR 4-N	50	60	60	48	M-10		7	150	10,0±1,0	20	12,0±1,0
	3617	60	70	58	52	M-12		10	350	11,0±1,0	70	11,0±1,0
	3356	60	80	65	72	M-12		10	600	13,0±1,5	120	13,0±1,5
	HR 5-N	50	80	70	68	M-14		11	350	14,0±1,5	65	14,0±1,5
	3866 RED	60	90	50	82	M-12		10	850	10,0±1,0	170	10,0±1,0
	3866	60	90	80	79	M-12		10	750	16,0±2,0	130	16,0±1,5
	HR 6-N	50	95	76	76	M-16		14	450	15,0±2,0	75	15,0±2,0
	3867	60	105	85	91	M-14		11	1200	17,0±2,0	240	17,0±2,0
	HR 7-N	50	108	75	97	M-16		14	600	15,0±2,0	140	15,0±2,0
HR 8-N	50	130	85	117	M-16		14	900	17,0±2,0	185	17,0±2,0	
3868	60	130	95	117	M-16		14	1800	19,0±2,0	320	19,0±2,0	
R-N	R 4-N	50	60	57	48	M-10	25		150	10,0±1,0		
	R 5-N	50	80	65	68	M-14	35		350	14,0±1,5		
	R 6-N	50	95	73	76	M-16	42		450	15,0±2,0		
TH-N	TH 4-N	50	60	58	48	M-10		7	150	10,0±1,0		
	TH 5-N	50	80	65	68	M-14		11	350	14,0±1,5		
	TH 6-N	50	95	73	76	M-16		14	450	15,0±2,0		

HR-N

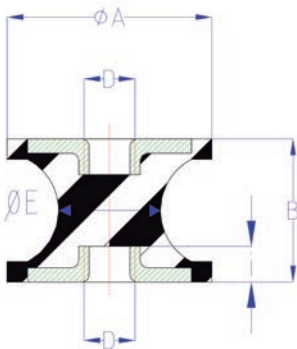

R-N

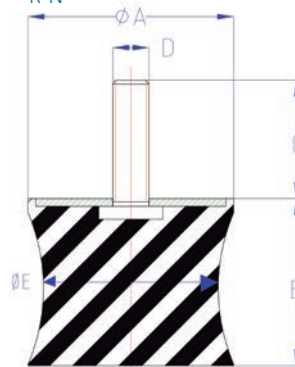

TH-N

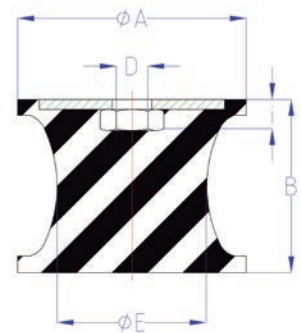

SB53 / SH / SB / SBH

SB-53	REF / ART.NR	DIMENSIONES / DIMENSIONS ABMESSUNGEN										COMPRESION / COMPRESSION DRUCKBELASTUNG	
		ØA	B	D	C	e	F	G	H	I	J	CARGA / LOAD CHARGE / LAST	FLECHA / DEFLECTION FLECHE / FEDERWEG
		mm.										kg.	mm.
	SB53 NR45 SB53 NR60 SB53 NR75	58	32	M-12	33	3	92	115	65	12		200 500 1000	7,0±1,0 7,0±1,0 7,0±1,0
SH	REF / ART.NR	DIMENSIONES / DIMENSIONS ABMESSUNGEN									COMPRESION / COMPRESSION DRUCKBELASTUNG		
		A	B	D	C1	C2	e	α	F	G	CARGA / LOAD CHARGE / LAST	FLECHA / DEFLECTION FLECHE / FEDERWEG	
		mm.									kg.	mm.	
	SH53 NR45 SH53 NR60	54	21	M-08	35	15	3	40°	36	30	40 90	9,0±1,0	
SB	REF / ART.NR	DIMENSIONES / DIMENSIONS ABMESSUNGEN										COMPRESION / COMPRESSION DRUCKBELASTUNG	
		ØA	B	D	C	e	F	G	H	I	J	CARGA / LOAD CHARGE / LAST	FLECHA / DEFLECTION FLECHE / FEDERWEG
		mm.										kg.	mm.
	SB35 NR45 SB35 NR60	30	25	M-08	20	1,5	67	90	55	13	9	50 100	4,5±1,0 4,5±1,0
	SB45 NR45 SB45 NR60	40	35	M-08	20	1,5	67	90	55	13	9	90 200	7,0±1,0 7,0±1,0
SBH	REF / ART.NR	DIMENSIONES / DIMENSIONS ABMESSUNGEN										COMPRESION / COMPRESSION DRUCKBELASTUNG	
		ØA	B	D	C	e	F	G	H	I	J	CARGA / LOAD CHARGE / LAST	FLECHA / DEFLECTION FLECHE / FEDERWEG
		mm.										kg.	mm.
	SBH35 NR45 SBH35 NR60	30	25	M-08		1,5	67	90	55	13	9	50 100	4,5±1,0 4,5±1,0
	SBH45 NR45 SBH45 NR60	40	35	M-08		1,5	67	90	55	13	9	90 200	7,0±1,0 7,0±1,0

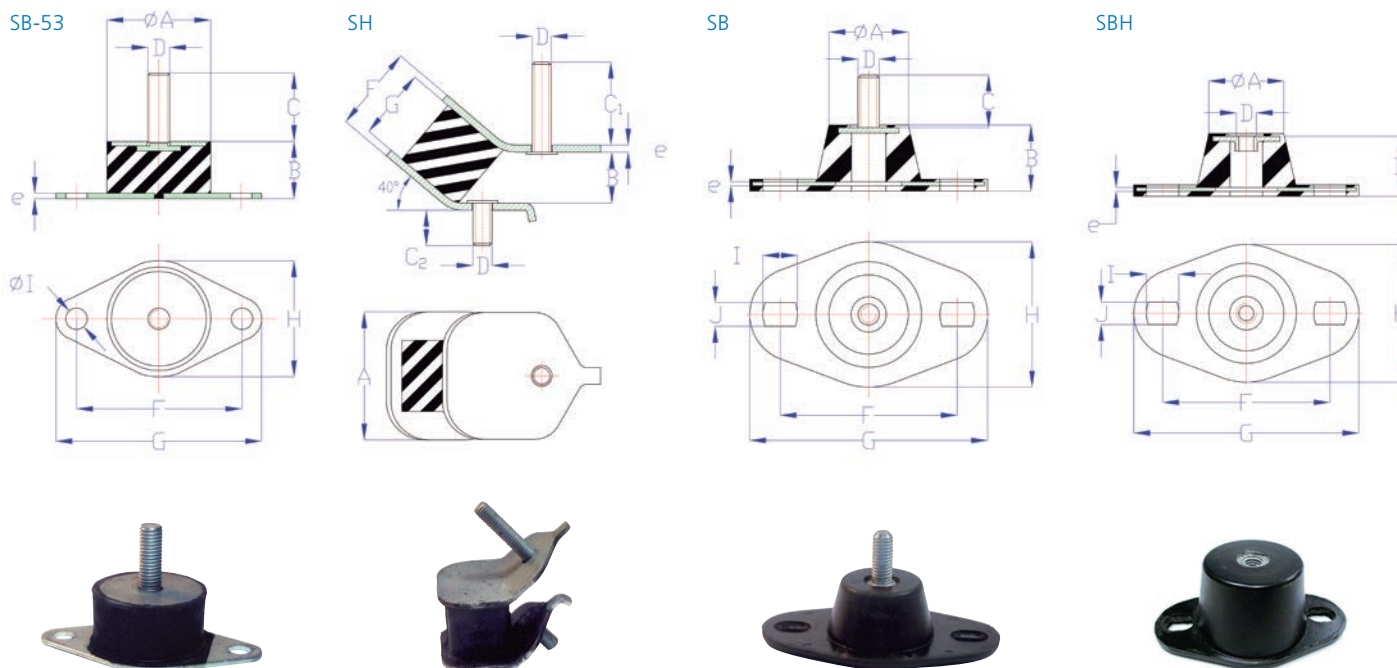

B

REF / ART.NR	DIMENSIONES / DIMENSIONS ABMESSUNGEN									COMPRESION / COMPRESSION DRUCKBELASTUNG	
	ØA	H	E	B	C	M	ØF	e	CARGA / LOAD CHARGE / LAST	FLECHA / DEFLECTION FLECHE / FEDERWEG	
	mm.									kg.	mm.
B045 + BAP040 NR35 B045 + BAP040 NR45 B045 + BAP040 NR60	40	18	20	52	64	M-06	6,2	2	2,5 5 10	2,5±0,5	
B065 + BAP060 NR45 B065 + BAP060 NR60 B065 + BAP060 NR75	60	22	24	76	90	M-06	6,2	2	15 25 50	3,5±0,5	
B085 + BAP080 NR45 B085 + BAP080 NR60 B085 + BAP080 NR75	80	25	27	100	120	M-08	8,2	2	40 80 120	4,5±0,5	
B105 + BAP100 NR45 B105 + BAP100 NR60 B105 + BAP100 NR75	100	25	28	124	148	M-10	10,2	2,5	75 160 220	4,5±1,0	
B155 + BAP150 NR45 B155 + BAP150 NR60 B155 + BAP150 NR75	150	35	40	182	214	M-14	11,8	4	130 300 400	7,0±1,5	
B205 + BAP200 NR45 B205 + BAP200 NR60 B205 + BAP200 NR75	200	40	44	240	280	M-18	15,0	5	500 850 1300	8,0±1,5	

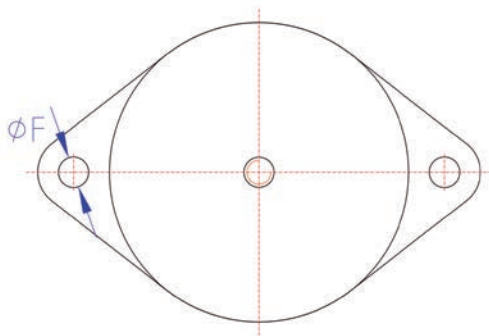
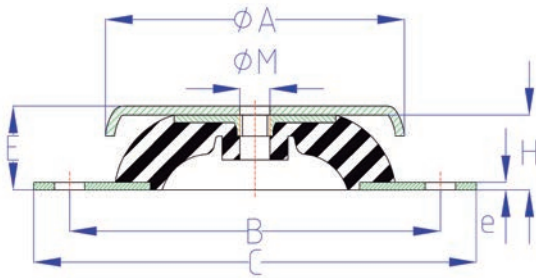

SCM

	REF / ART.NR		DIMENSIONES / DIMENSIONS ABMESSUNGEN						CARGA ESTÁTICA / STATIC LOAD CHARGE STATIQUE / STATISCHE LAST		CARGA DINÁMICA / DYNAMIC LOAD / CHARGE DYNAMIQUE / DYNAMISCHE LAST		
	Sh		ØA	B	D	C	ØE	F	j	CARGA / LOAD CHARGE / LAST	FLECHA / DEFLECTION FLECHE / FEDERWEG	CARGA / LOAD CHARGE / LAST	FLECHA / DEFLECTION FLECHE / FEDERWEG
	mm.						kg.	mm.	kg.	mm.			
SCM	SCM060 NR	35								35	3,0±0,5	25	2,0±0,5
	SCM060 NR	45								60	3,0±0,5	45	2,0±0,5
	SCM060 NR	60								125	3,0±0,5	100	2,0±0,5
	SCM060 NR	75	50	28	50	M-08	6	60	1,5	200	3,0±0,5	150	2,0±0,5
	SCM060 VMQ	45								75	3,0±0,5	50	2,0±0,5
	SCM060 VMQ	60								100	3,0±0,5	75	2,0±0,5
	SCM060 VMQ	75								150	3,0±0,5	120	2,0±0,5
	SCP120L VMQ	55								170	3,5±0,5	100	2,5±0,5
	SCP120L VMQ	65	76	38	63,5	M-10	6,5	76	3	375	3,5±0,5	200	2,5±0,5
	SCP120L VMQ	75								575	3,5±0,5	300	2,5±0,5
	SCM120 NR	45								80	3,5±0,5	60	2,5±0,5
	SCM120 NR	60								200	3,5±0,5	150	2,5±0,5
	SCM120 NR	75								300	3,5±0,5	225	2,5±0,5
	SCM120 VMQ	45	76	41	72	M-10	9	90	3	80	3,5±0,5	60	2,5±0,5
	SCM120 VMQ	60								160	3,5±0,5	120	2,5±0,5
	SCM120 VMQ	75								250	3,5±0,5	180	2,5±0,5
	SCM220 NR	45								170	4,5±0,5	130	3,5±0,5
	SCM220 NR	60								300	4,5±0,5	225	3,5±0,5
	SCM220 NR	75								450	4,5±0,5	330	3,5±0,5
	SCM220 VMQ	45	92	53	90	M-12	11	114	3	130	4,5±0,5	100	3,5±0,5
	SCM220 VMQ	60								220	4,5±0,5	165	3,5±0,5
	SCM220 VMQ	75								350	4,5±0,5	265	3,5±0,5
	SCM420 NR	45								350	6,5±1,0	250	4,5±1,0
	SCM420 NR	60								800	6,5±1,0	550	4,5±1,0
SCM420 NR	75								1400	6,5±1,0	900	4,5±1,0	
SCM420 VMQ	45	124	78	114	M-16	13	144	4	350	6,5±1,0	250	4,5±1,0	
SCM420 VMQ	60								800	6,5±1,0	550	4,5±1,0	
SCM420 VMQ	75								1100	6,5±1,0	750	4,5±1,0	

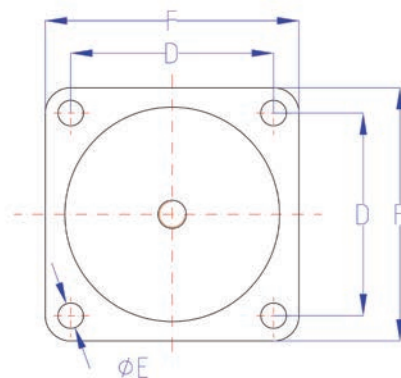
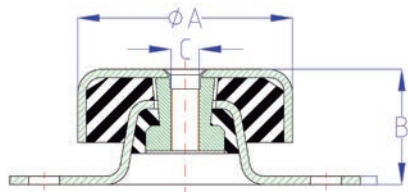

SCM

	REF / ART.NR		DIMENSIONES / DIMENSIONS ABMESSUNGEN										CARGA ESTÁTICA / STATIC LOAD CHARGE STATIQUE / STATISCHE LAST		CARGA DINÁMICA / DYNAMIC LOAD / CHARGE DYNAMIQUE / DYNAMISCHE LAST	
	Sh	ØA	B	D	C	F	j	m	n	o	d	CARGA / LOAD CHARGE / LAST	FLECHA / DEFLECTION FLECHE / FEDERWEG	CARGA / LOAD CHARGE / LAST	FLECHA / DEFLECTION FLECHE / FEDERWEG	
	mm.										kg.	mm.	kg.	mm.		
SCM	SCM125 NR	45										80	3,5±0,5	60	2,5±0,5	
	SCM125 NR	60										200	3,5±0,5	150	2,5±0,5	
	SCM125 NR	75										300	3,5±0,5	225	2,5±0,5	
	SCM125 VMQ	45	76	41	100	M-10	124	3	11	14	14	11	80	3,5±0,5	60	2,5±0,5
	SCM125 VMQ	60										160	3,5±0,5	120	2,5±0,5	
	SCM125 VMQ	75										250	3,5±0,5	180	2,5±0,5	
	SCM225 NR	45											170	4,5±0,5	130	3,5±0,5
	SCM225 NR	60											300	4,5±0,5	225	3,5±0,5
	SCM225 NR	75											450	4,5±0,5	330	3,5±0,5
	SCM225 VMQ	45	92	53	140	M-12	183	3	13	30	20	13	130	4,5±0,5	100	3,5±0,5
	SCM225 VMQ	60											220	4,5±0,5	165	3,5±0,5
	SCM225 VMQ	75											350	4,5±0,5	265	3,5±0,5
	SCM325 NR	45											120	4,5±0,5	95	3,5±0,5
	SCM325 NR	60											210	4,5±0,5	160	3,5±0,5
	SCM325 NR	75											330	4,5±0,5	260	3,5±0,5
	SCM325 VMQ	45	92	53	115	M-12	140	3	11	11	11	11	130	4,5±0,5	100	3,5±0,5
	SCM325 VMQ	60											220	4,5±0,5	165	3,5±0,5
	SCM325 VMQ	75											350	4,5±0,5	265	3,5±0,5
	SCM425 NR	45											350	6,5±1,0	250	4,5±1,0
	SCM425 NR	60											800	6,5±1,0	550	4,5±1,0
	SCM425 NR	75											1400	6,5±1,0	900	4,5±1,0
	SCM425 VMQ	45	124	78	182	M-16	230	4	18	34	26	18	350	6,5±1,0	250	4,5±1,0
	SCM425 VMQ	60											800	6,5±1,0	550	4,5±1,0
	SCM425 VMQ	75											1100	6,5±1,0	750	4,5±1,0

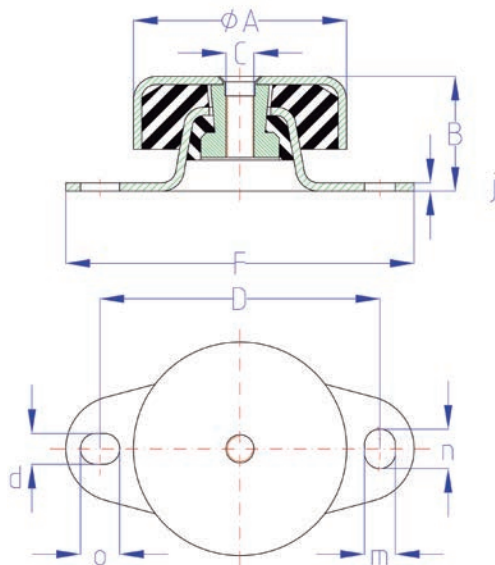

SCC

REF / ART.NR	DIMENSIONES / DIMENSIONS ABMESSUNGEN									COMPRESION / COMPRESSION DRUCKBELASTUNG	
	Sh	ØA	H	L	M	F	e	m	n	CARGA / LOAD CHARGE / LAST	FLECHA / DEFLECTION FLECHE / FEDERWEG
	mm.									kg.	mm.
SCC080	35	83	35	110	M-10	135	3	11,5	15	80	4,5±1,0
SCC080	45									130	4,5±1,0
SCC080	60									175	4,5±1,0
SCC080	75									230	3,5±1,0
SCC080	35	83	35	110	M-12	135	3	11,5	15	80	4,5±1,0
SCC080	45									130	4,5±1,0
SCC080	60									175	4,5±1,0
SCC080	75									230	3,5±1,0
SCC095	35	92	34	123	M-10	150	3	10,0	15	200	5,0±1,0
SCC095	45									300	5,0±1,0
SCC095	60									600	5,0±1,0
SCC095	75									900	5,0±1,0
SCC095	35	92	34	123	M-12	150	3	10,0	15	200	5,0±1,0
SCC095	45									300	5,0±1,0
SCC095	60									600	5,0±1,0
SCC095	75									900	5,0±1,0
SCC110	35	106	41	143	M-12	169	3	12,5	19	200	7,0±1,0
SCC110	45									340	7,0±1,0
SCC110	60									420	7,0±1,0
SCC110	65									425	5,0±1,0
SCC110	75									800	5,0±1,0
SCC110	35	106	41	143	M-16	169	3	12,5	19	200	7,0±1,0
SCC110	45									340	7,0±1,0
SCC110	60									420	7,0±1,0
SCC110	65									425	5,0±1,0
SCC110	75									800	5,0±1,0
SCC150	35	150	54	182	M-16	218	4	14,0	18	450	9,0±1,5
SCC150	45									600	9,0±1,5
SCC150	60									800	8,0±1,5
SCC150	65									1000	8,0±1,5
SCC150	75									1000	6,0±1,5

SCC

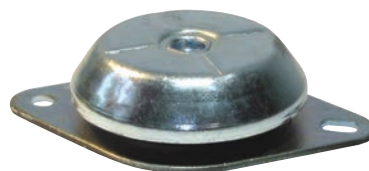
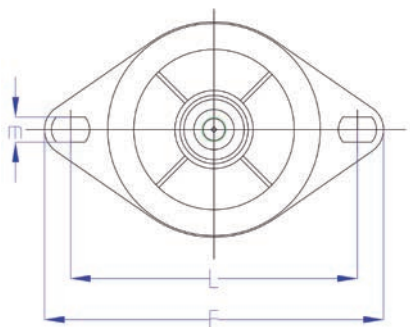
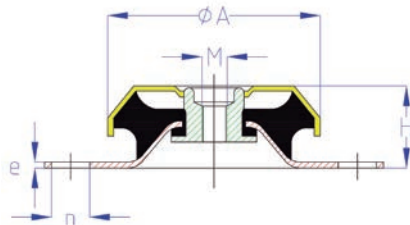

LC

LC	REF / ART.NR		DIMENSIONES / DIMENSIONS ABMESSUNGEN										CARGA ESTÁTICA / STATIC LOAD CHARGE STATIQUE / STATISCHE LAST		RELACIÓN RIGIDEZ STIFFNESS RATIO RELATION RIGIDITE STEIFIGKEITSVERHÄLTNIS		
	Sh	ØA	B	ØD	C	e	ØF	ØG	H	I	J	ØK	CARGA / LOAD CHARGE / LAST	FLECHA / DEFLECTION FLECHE / FEDERWEG	Kx	Ky	Kz
	mm.												kg.	mm.			
LC102	35												50	3,5±0,5	1	1,1	1,9
	45												80	3,5±0,5	1	1,1	1,9
	55	66	45	10,3	12	2,5	25,5	12,8	82,5	102	70	57	120	3,5±0,5	1	1,1	1,9
	65												170	3,5±0,5	1	1,1	1,9
	75												215	3,5±0,5	1	1,1	1,9
LC122	35												95	4,5±0,5	1	1,1	1,9
	45												125	4,5±0,5	1	1,1	1,9
	55	70	50	10,4	16	3	25,5	12,8	100	122	75	57	150	4,5±0,5	1	1,1	1,9
	65												260	4,5±0,5	1	1,1	1,9
	75												375	4,5±0,5	1	1,1	1,9
LC170	35												180	6,0±1,0	1	1,1	1,9
	45												240	6,0±1,0	1	1,1	1,9
	55	95	70	13,0	18	3	34,0	22,0	141	170	100	74	350	6,0±1,0	1	1,1	1,9
	65												540	6,0±1,0	1	1,1	1,9
	75												700	6,0±1,0	1	1,1	1,9
LC302	35												55	3,5±0,5	1	1,9	1,9
	45												100	3,5±0,5	1	1,9	1,9
	55	66	45	10,3	12	2,5	25,5	12,8	82,5	102	70	57	140	3,5±0,5	1	1,9	1,9
	65												180	3,5±0,5	1	1,9	1,9
	75												350	3,5±0,5	1	1,9	1,9

AC	REF / ART.NR		DIMENSIONES / DIMENSIONS ABMESSUNGEN			
	Sh	ØA	B	e	ØG	
	mm.					
	AC102	60	8	5	13	
	AC170	75	8	5	21	
AR	AR102	47	6,5		13	
	AR170	62	7		23	

Arandelas de centrado y de rebote
Overload and rebound washers
Rondelles progressives et de rebond
Überlastungs- und Rückstosscheiben

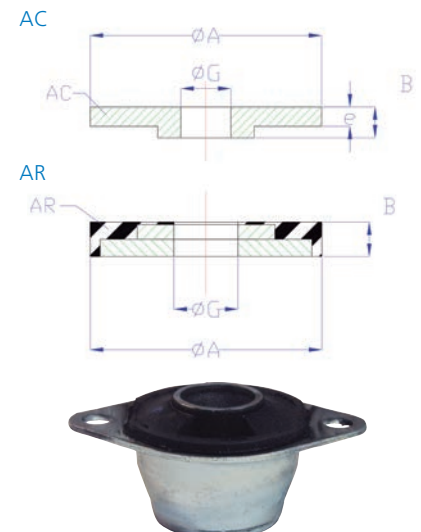
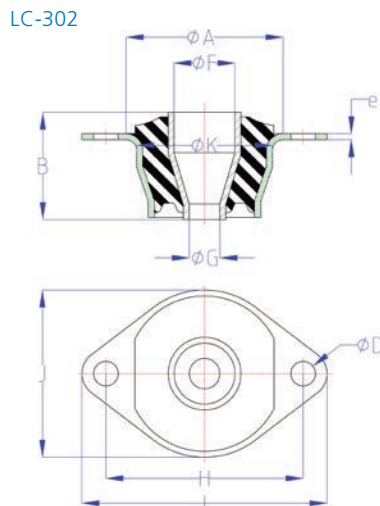
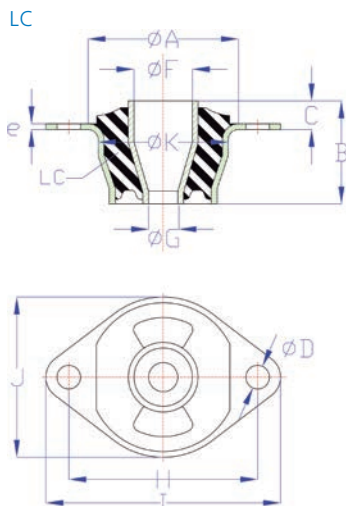

SC

SC	REF / ART.NR		DIMENSIONES / DIMENSIONS ABMESSUNGEN						DUREZA / HARDNESS DURETÉ / HÄRTEN 45 Shöre		DUREZA / HARDNESS DURETÉ / HÄRTEN 60 Shöre		DUREZA / HARDNESS DURETÉ / HÄRTEN 75 Shöre		
	Fig.		ØA	B	C	D	ØE	ØF	G	CARGA LOAD CHARGE LAST	FLECHA DEFLECTION FLECHE FEDERWEG	CARGA LOAD CHARGE LAST	FLECHA DEFLECTION FLECHE FEDERWEG	CARGA LOAD CHARGE LAST	FLECHA DEFLECTION FLECHE FEDERWEG
	mm.														
	SC-00	2	32	28	13,5	11	8,25	26	12	20	1,5±0,2	30	1,2±0,2	40	0,8±0,1
	SC-02	1	48	51	24	18	12,50	38	8	65	2,5±0,5	85	2,0±0,5	110	2,0±0,5
	SC-20	1	70	55	27	19	18,50	56	10	100	3,5±0,5	150	3,0±0,5	180	2,5±0,5
	SC-21	1	70	70	39	19	18,50	56	10	125	3,5±0,5	200	3,0±0,5	250	2,5±0,5
	SC-40	1	100	90	42	28	22,50	74	19	200	5,0±0,5	350	4,5±0,5	400	3,5±0,5
	SC-41	1	100	110	49	28	22,50	74	19	225	5,0±0,5	375	5,0±0,5	450	3,5±0,5
	SC-70 red	1	165	98	36	46	60,20	119	22	450	6,5±1,0	800	5,5±1,0	1000	3,5±0,5
	SC-70	1	165	140	66	46	60,20	119	22	450	6,5±1,0	900	5,5±1,0	1100	3,5±0,5

Fig. 1

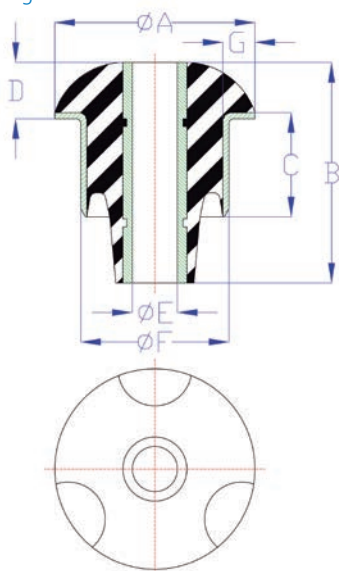
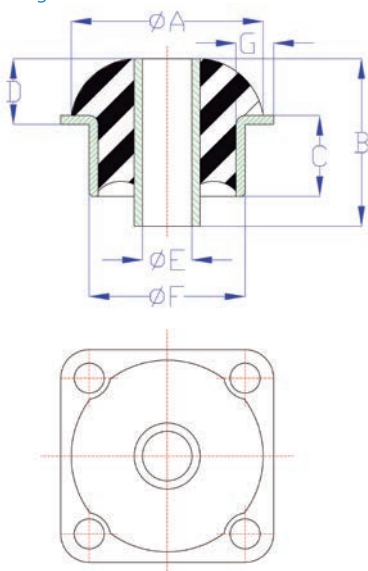

Fig. 2



AMORTIGUADORES / ANTIVIBRATION MOUNTS / AMORTISSEURS / SCHWINGUNGSDÄMPFER

G	REF / ART.NR		DIMENSIONES / DIMENSIONS ABMESSUNGEN					COMPRESION / COMPRESSION DRUCKBELASTUNG	
		Sh	A	B	C	D	ØE	CARGA / LOAD CHARGE / LAST	FLECHA / DEFLECTION FLECHE / FEDERWEG
	mm.							kg.	mm.
	G051	60	50	50	15			250	3,0±0,5
	G512	60	50	50	15		20	200	3,0±0,5
	G052	60	50	50	20			250	4,0±0,5
	G522	60	50	50	20		20	200	4,0±0,5
	G070	60	70	70	35			600	7,0±1,0
	G080	60	80	80	45	30		900	9,0±1,0
	G082	60	80	80	25			900	5,0±1,0
	G823	60	80	80	25		30	750	5,0±1,0
	G085	60	80	80	35			900	7,0±1,0
	G853	60	80	80	35		30	750	7,0±1,0
	G106	60	100	100	60			1400	12,0±1,5
	G1064	60	100	100	60		40	1200	12,0±1,5

ALF	REF / ART.NR		DIMENSIONES / DIMENSIONS ABMESSUNGEN				COMPRESION / COMPRESSION DRUCKBELASTUNG	
		SH	A	B	C			
	mm.					kg.	mm.	
	ALF300	60	300	300	8	1000	1,6±0,5	
	ALF400	60	400	400	12	2000	2,4±0,5	

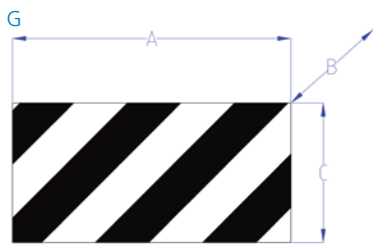

ALF 300

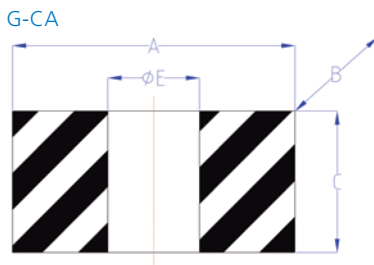
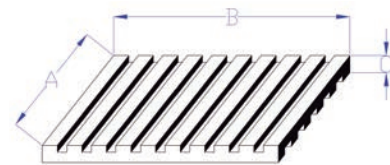

ALF 400

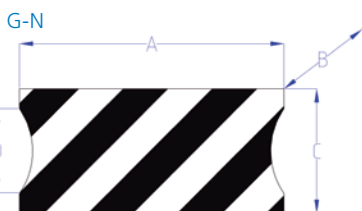
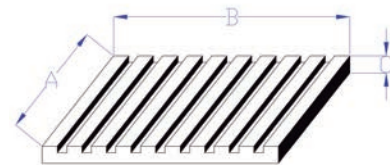

AMORTIGUADORES / ANTIVIBRATION MOUNTS / AMORTISSEURS / SCHWINGUNGSDÄMPFER

G	REF / ART.NR	DIMENSIONES / DIMENSIONS ABMESSUNGEN				COMPRESION / COMPRESSION DRUCKBELASTUNG	
		SH	ØA	B	C	CARGA / LOAD CHARGE / LAST	FLECHA / DEFLECTION FLECHE / FEDERWEG
		mm.				kg.	mm.
	G3870	60	140	45	127	2000	9,0±1,0
	G3869	60	150	46	138	2500	9,0±1,0

G	REF / ART.NR	DIMENSIONES / DIMENSIONS ABMESSUNGEN							COMPRESION / COMPRESSION DRUCKBELASTUNG	
		A	B	C	ØE	F	G	H	CARGA / LOAD CHARGE / LAST	FLECHA / DEFLECTION FLECHE / FEDERWEG
		mm.							kg.	mm.
	G3871-60SH	295	117	60	35	150	72,5	59	7000	12,0±1,5

G3870-G3869

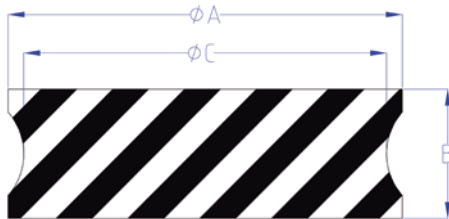

G3871

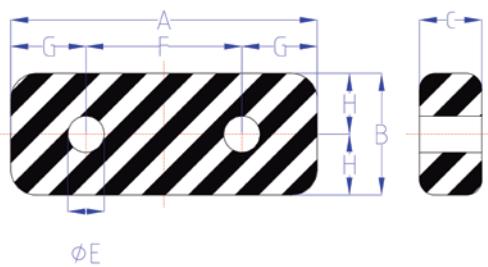

AMORTIGUADORES / ANTIVIBRATION MOUNTS / AMORTISSEURS / SCHWINGUNGSDÄMPFER

P	REF / ART.NR	DIMENSIONES / DIMENSIONS ABMESSUNGEN							COMPRESION / COMPRESSION DRUCKBELASTUNG		
		A	B	C	ØD3	E	ØD2	ØD1	e	CARGA / LOAD CHARGE / LAST	FLECHA / DEFLECTION FLECHE / FEDERWEG
		mm							kg.	mm.	
	P	93	77	160	14	132	35	50	8	2500	15,0±2,0

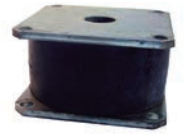
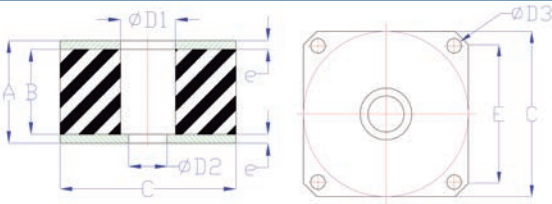

M	REF / ART.NR	DIMENSIONES / DIMENSIONS ABMESSUNGEN				COMPRESION / COMPRESSION DRUCKBELASTUNG	
		SH	L	M	N	CARGA / LOAD CHARGE / LAST	FLECHA / DEFLECTION FLECHE / FEDERWEG
		mm.				kg.	mm.
	M	60	350	200	70	10000	10,0±1,0

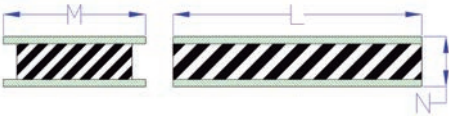

ANT.M	REF / ART.NR	DIMENSIONES / DIMENSIONS ABMESSUNGEN				COMPRESION / COMPRESSION DRUCKBELASTUNG	
		SH	L	M	N	CARGA / LOAD CHARGE / LAST	FLECHA / DEFLECTION FLECHE / FEDERWEG
		mm.				kg.	mm.
	ANT.M	60	350	200	22	7000	3,0±0,5

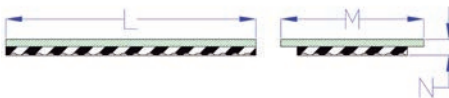

B	REF / ART.NR	DIMENSIONES / DIMENSIONS ABMESSUNGEN				COMPRESION / COMPRESSION DRUCKBELASTUNG	
		SH	L	M	N	CARGA / LOAD CHARGE / LAST	FLECHA / DEFLECTION FLECHE / FEDERWEG
		mm.				kg.	mm.
	B	45	500	100	60	3800	8,0±1,0
	B	60	500	100	60	6250	8,0±1,0
	B	75	500	100	60	12000	8,0±1,0

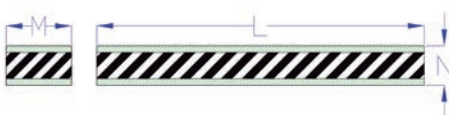

RTK / OP

RTK	REF / ART.NR		DIMENSIONES / DIMENSIONS ABMESSUNGEN										COMPRESION / COMPRESSION DRUCKBELASTUNG	
		Sh	A	B	ØC	ØD	e	F	G	H	I	J	CARGA / LOAD CHARGE / LAST	FLECHA / DEFLECTION FLECHE / FEDERWEG
	mm.												kg.	mm.
	RTK58517/2	60	190	32	93	18,2	3	140	15	25	M-8	5	1200	6,5±1,0
	RTK58517	75	190	45	93	18,2	3	140	15	25	M-8	5	2000	9,0±1,0

OP	REF / ART.NR	COMPRESION / COMPRESSION DRUCKBELASTUNG	
		CARGA / LOAD CHARGE / LAST	FLECHA / DEFLECTION FLECHE / FEDERWEG
		kg.	mm.
	OP37974	4000	10,0±1,0

RTK

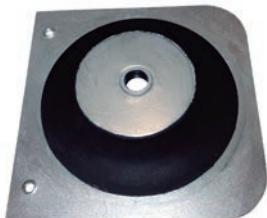
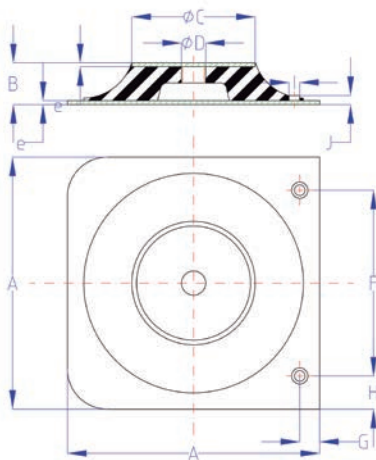

OP

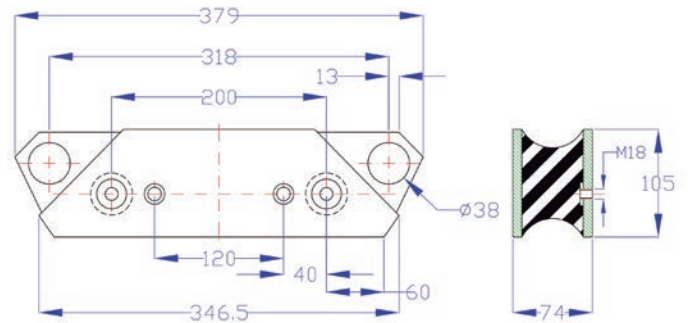

RTP

RTP	REF / ART.NR		DIMENSIONES / DIMENSIONS ABMESSUNGEN					COMPRESION / COMPRESSION DRUCKBELASTUNG	
		Sh	ØA	B	M	D	E	CARGA / LOAD CHARGE / LAST	FLECHA / DEFLECTION FLECHE / FEDERWEG
	mm.							kg.	mm.
	RTP 2	60	84	52	M-12	35	30	600	5,0±0,5
	RTP 4	60	120	75	M-16	50	35	1500	9,0±1,5
	RTP 6	60	220	136	M-24	80	57	4500	14,0±1,5

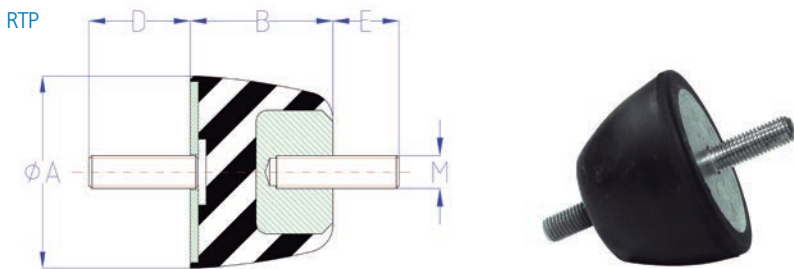

CRTP	REF / ART.NR		DIMENSIONES / DIMENSIONS ABMESSUNGEN			
	CAMPANA / METAL CUP CLOCHE / METALLKAPPE	ØC	F	ØH	G	
	mm.					
	RTP 2	90	50	12	3	
	RTP 4	130	76	16	5	
	RTP 6	246	140	14	8	

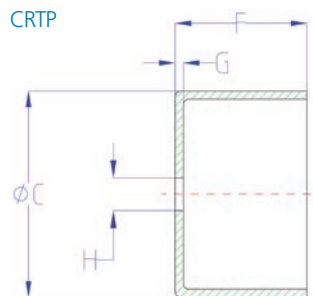

caRTP	REF / ART.NR		DIMENSIONES / DIMENSIONS ABMESSUNGEN				
	CASQUILLO DE CENTRAJE METAL BUSH / DOUILLE METALLBUCHSE	ØX	ØJ	ØP	L	R	S
	mm.						
	RTP 2	25	12	20	13	9	4
	RTP 4	35	16	25	24	18	6

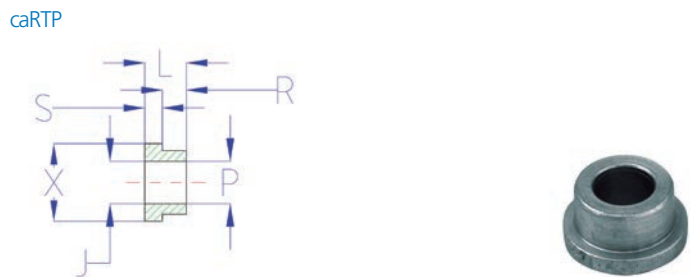

RTP4-A	REF / ART.NR		DIMENSIONES / DIMENSIONS ABMESSUNGEN	
	RTP 4-A		CARGA / LOAD CHARGE / LAST	
			Kg.	
	RTP 4-A		1500	

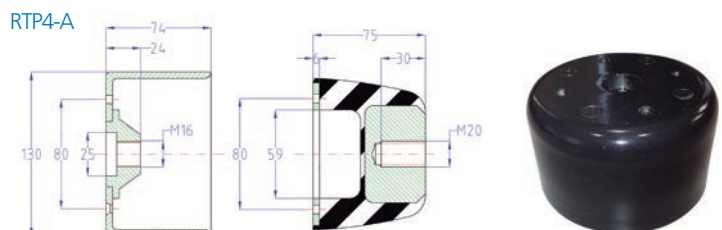

N T2 / M T2

	REF / ART.NR	DIMENSIONES / DIMENSIONS ABMESSUNGEN				COMPRESION / COMPRESSION DRUCKBELASTUNG		CONSTANTE / STIFFNESS RIGIDITE / STEIFIGKEIT
		ØA	B	D	C	CARGA / LOAD CHARGE / LAST	FLECHA / DEFLECTION FLECHE / FEDERWEG	
	mm.				kg.	mm.	kg./cm	
N T2	N10 T2	55	59	M-08	25	10	11±2,0	9,09
	N15 T2	55	59	M-08	25	15	11±2,0	13,64
	N25 T2	55	59	M-08	25	25	11±2,0	22,73
	N50 T2	55	59	M-08	25	50	11±2,0	45,45
	N75 T2	55	59	M-08	25	75	11±2,0	68,18
	N100 T2	55	59	M-08	25	100	11±2,0	90,91
	N152 T2	73	91	M-12	33	150	13±2,0	115,38
	N252 T2	73	91	M-12	33	250	13±2,0	192,31
	N352 T2	73	91	M-12	33	350	13±2,0	269,23
M T2	M25 T2	55	79	M-08	25	25	20±2,0	12,50
	M50 T2	55	79	M-08	25	50	20±2,0	25,00
	M75 T2	55	79	M-08	25	75	20±2,0	37,50
	M100 T2	55	79	M-08	25	100	20±2,0	50,00
	M125 T2	55	79	M-08	25	125	20±2,0	62,50
	M152 T2	73	120	M-12	33	150	30±3,0	50,00
	M202 T2	73	120	M-12	33	200	30±3,0	66,67
	M252 T2	73	120	M-12	33	250	30±3,0	83,33
	M352 T2	73	120	M-12	33	350	30±3,0	116,67
	M452 T2	73	120	M-12	33	450	30±3,0	150,00
	M552 T2	73	120	M-12	33	550	30±3,0	183,33

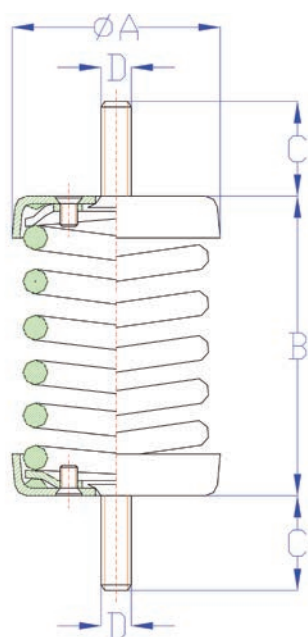

METÁLICOS / RESSORTS / SPRINGS / FEDERISOLATOREN N (10 - 350 kg.)

REF / ART.NR	DIMENSIONES / DIMENSIONS ABMESSUNGEN								COMPRESION / COMPRESSION DRUCKBELASTUNG		CONSTANTE / STIFFNESS RIGIDITE / STEIFIGKEIT
	ØA	B	C	D	E	F	G	M	CARGA / LOAD CHARGE / LAST	FLECHA / DEFLECTION FLECHE / FEDERWEG	
	mm.								kg.	mm.	kg./cm
N10	55	59						8	10	11±2,0	9,09
N15	55	59						8	15	11±2,0	13,64
N25	55	59						8	25	11±2,0	22,73
N50	55	59						8	50	11±2,0	45,45
N75	55	59						8	75	11±2,0	68,18
N100	55	59						8	100	11±2,0	90,91
N152	73	91						12	150	13±2,0	115,39
N252	73	91						12	250	13±2,0	192,31
N352	73	91						12	350	13±2,0	269,23
N10 B	55	61	90	55	70	10	10	8	10	11±2,0	9,09
N15 B	55	61	90	55	70	10	10	8	15	11±2,0	13,64
N25 B	55	61	90	55	70	10	10	8	25	11±2,0	22,73
N50 B	55	61	90	55	70	10	10	8	50	11±2,0	45,45
N75 B	55	61	90	55	70	10	10	8	75	11±2,0	68,18
N100 B	55	61	90	55	70	10	10	8	100	11±2,0	90,91
N150 B	73	94	110	75	89	11	10	12	150	13±2,0	115,38
N250 B	73	94	110	75	89	11	10	12	250	13±2,0	192,31
N350 B	73	94	110	75	89	11	10	12	350	13±2,0	269,23
N10 BB		63	90	55	70	10	10	8	10	11±2,0	9,09
N15 BB		63	90	55	70	10	10	8	15	11±2,0	13,64
N25 BB		63	90	55	70	10	10	8	25	11±2,0	22,73
N50 BB		63	90	55	70	10	10	8	50	11±2,0	45,45
N75 BB		63	90	55	70	10	10	8	75	11±2,0	68,18
N100 BB		63	90	55	70	10	10	8	100	11±2,0	90,91
N151 BB		95	110	75	89	11	10	12	150	13±2,0	115,38
N251 BB		95	110	75	89	11	10	12	250	13±2,0	192,31
N351 BB		95	110	75	89	11	10	12	350	13±2,0	269,23

N

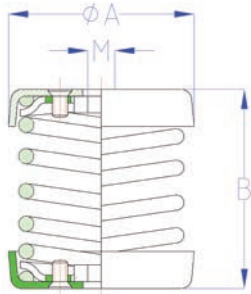

NB

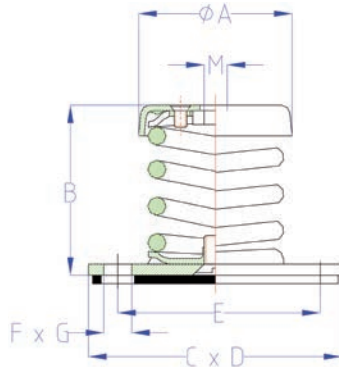

NBB

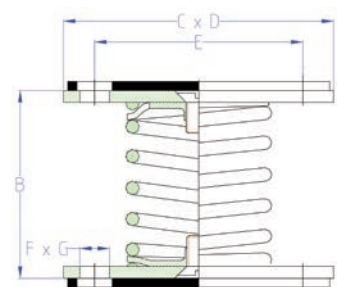

2N / 3N / 4N (300 - 1400 kg.)

	REF / ART.NR	CARGA / LOAD CHARGE / LAST	FLECHA / DEFLECTION FLÈCHE / FEDERWEG	CONSTANTE / STIFFNESS RIGIDITE / STEIFIGKEIT
		kg.	mm.	kg./cm
2N	2N 300	300	13±2,0	230,77
	2N 500	500	13±2,0	384,62
	2N 700	700	13±2,0	538,46
3N	3N 450	450	13±2,0	346,15
	3N 750	750	13±2,0	576,92
	3N 1050	1050	13±2,0	807,69
4N	4N 600	600	13±2,0	461,54
	4N 1000	1000	13±2,0	769,23
	4N 1400	1400	13±2,0	1076,92

2N

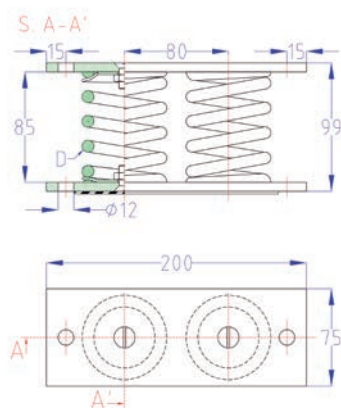

3N

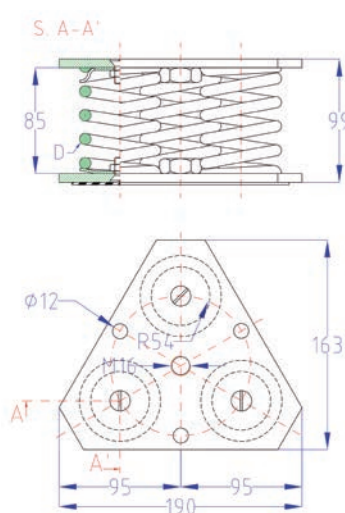

4N

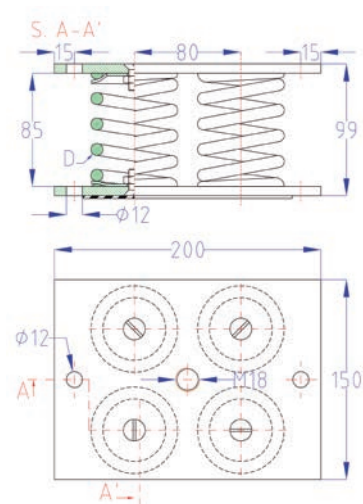

5N / 6N / 9N (750 - 3150 kg.)

	REF / ART.NR	CARGA / LOAD	FLECHA / DEFLECTION	CONSTANTE / STIFFNESS
		CHARGE / LAST	FLÈCHE / FEDERWEG	RIGIDITE / STEIFIGKEIT
		kg.	mm.	kg./cm
5N	5N 750	750	13±2,0	576,92
	5N 1250	1250	13±2,0	961,54
	5N 1750	1750	13±2,0	1346,15
6N	6N 900	900	13±2,0	692,31
	6N 1500	1500	13±2,0	1153,85
	6N 2100	2100	13±2,0	1615,38
9N	9N 1350	1350	13±2,0	1038,46
	9N 2250	2250	13±2,0	1730,77
	9N 3150	3150	13±2,0	2423,08

5 N

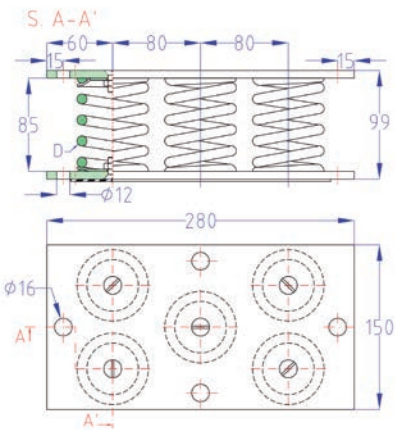

6 N

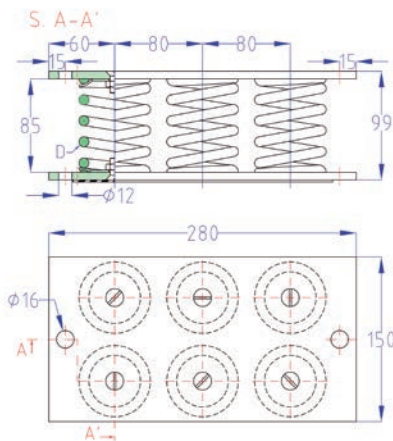

9 N

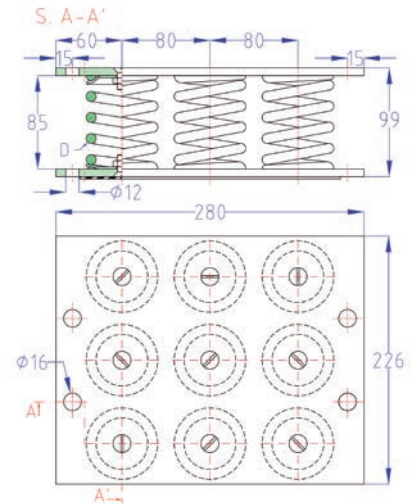

METÁLICOS / RESSORTS / SPRINGS / FEDERISOLATOREN M (25 - 550 kg.)

M	REF / ART.NR	DIMENSIONES / DIMENSIONS ABMESSUNGEN							COMPRESION / COMPRESSION DRUCKBELASTUNG		CONSTANTE / STIFFNESS RIGIDITE / STEIFIGKEIT	
		ØA	B	C	D	E	F	G	M	CARGA / LOAD CHARGE / LAST	FLECHA / DEFLECTION FLECHE / FEDERWEG	
		mm.							kg.	mm.	kg./cm	
	M25	55	79						8	25	20±2,0	12,50
	M50	55	79						8	50	20±2,0	25,00
	M75	55	79						8	75	20±2,0	37,50
	M100	55	79						8	100	20±2,0	50,00
	M125	55	79						8	125	20±2,0	62,50
	M152	73	116						12	150	30±3,0	50,00
	M202	73	116						12	200	30±3,0	66,67
	M252	73	116						12	250	30±3,0	83,33
	M352	73	116						12	350	30±3,0	116,67
	M452	73	116						12	450	30±3,0	150,00
	M552	73	116						12	550	30±3,0	183,33
	M25 B	55	81	90	55	70	10	10	8	25	20±2,0	12,50
	M50 B	55	81	90	55	70	10	10	8	50	20±2,0	25,00
	M75 B	55	81	90	55	70	10	10	8	75	20±2,0	37,50
	M100 B	55	81	90	55	70	10	10	8	100	20±2,0	50,00
	M125 B	55	81	90	55	70	10	10	8	125	20±2,0	62,50
	M150 B	73	119	110	75	89	11	10	12	150	30±3,0	50,00
	M200 B	73	119	110	75	89	11	10	12	200	30±3,0	66,67
	M250 B	73	119	110	75	89	11	10	12	250	30±3,0	83,33
	M350 B	73	119	110	75	89	11	10	12	350	30±3,0	116,67
	M450 B	73	119	110	75	89	11	10	12	450	30±3,0	150,00
	M550 B	73	119	110	75	89	11	10	12	550	30±3,0	183,33
	M25 BB		83	90	55	70	10	10		25	20±2,0	12,50
	M50 BB		83	90	55	70	10	10		50	20±2,0	25,00
	M75 BB		83	90	55	70	10	10		75	20±2,0	37,50
	M100 BB		83	90	55	70	10	10		100	20±2,0	50,00
	M125 BB		83	90	55	70	10	10		125	20±2,0	62,50
	M151 BB		120	110	75	89	11	10		150	30±3,0	50,00
	M201 BB		120	110	75	89	11	10		200	30±3,0	66,67
	M251 BB		120	110	75	89	11	10		250	30±3,0	83,33
	M351 BB		120	110	75	89	11	10		350	30±3,0	116,67
	M451 BB		120	110	75	89	11	10		450	30±3,0	150,00
	M551 BB		120	110	75	89	11	10		550	30±3,0	183,33

M

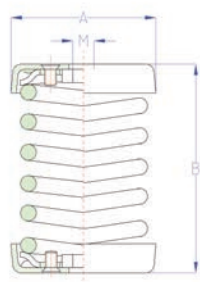

MB

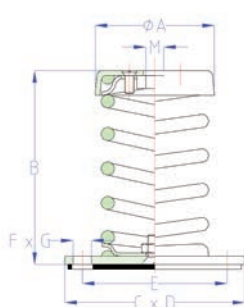

MBB

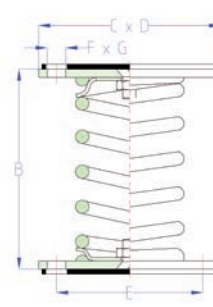

2M / 3M / 4M (300 - 2200 kg.)

	REF / ART.NR	CARGA / LOAD CHARGE / LAST	FLECHA / DEFLECTION FLÈCHE / FEDERWEG	CONSTANTE / STIFFNESS RIGIDITE / STEIFIGKEIT
		kg.	mm.	kg./cm
2M	2M 300	300	30±3,0	100,00
	2M 400	400	30±3,0	130,33
	2M 500	500	30±3,0	166,67
	2M 700	700	30±3,0	233,33
	2M 900	900	30±3,0	300,00
	2M 1100	1100	30±3,0	366,66
3M	3M 450	450	30±3,0	150,00
	3M 600	600	30±3,0	200,00
	3M 750	750	30±3,0	250,00
	3M 1050	1050	30±3,0	350,00
	3M 1350	1350	30±3,0	450,00
	3M 1650	1650	30±3,0	550,00
4M	4M 600	600	30±3,0	200,00
	4M 800	800	30±3,0	266,67
	4M 1000	1000	30±3,0	333,33
	4M 1400	1400	30±3,0	466,67
	4M 1800	1800	30±3,0	600,00
	4M 2200	2200	30±3,0	733,33

2M

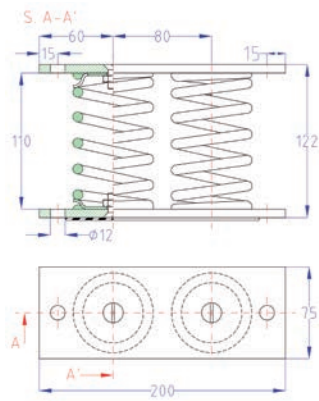

3M

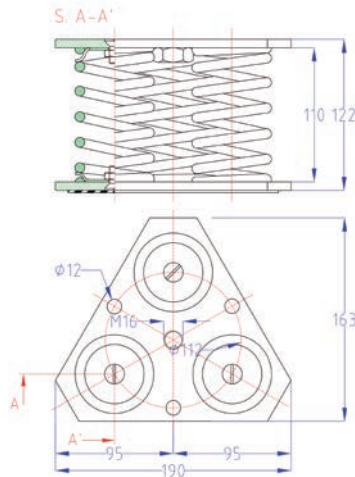

4M

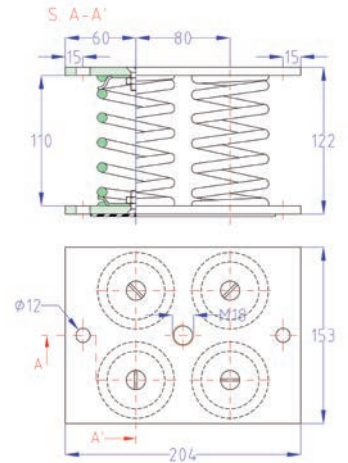

5M / 6M / 9M (750 - 4950 kg.)

	REF / ART.NR	CARGA / LOAD CHARGE / LAST	FLECHA / DEFLECTION FLÈCHE / FEDERWEG	CONSTANTE / STIFFNESS RIGIDITE / STEIFIGKEIT
		kg.	mm.	kg./cm
5M	5M 750	750	30±3,0	250,00
	5M 1000	1000	30±3,0	333,33
	5M 1250	1250	30±3,0	416,67
	5M 1750	1750	30±3,0	583,33
	5M 2250	2250	30±3,0	750,00
	5M 2750	2750	30±3,0	916,67
6M	6M 900	900	30±3,0	300,00
	6M 1200	1200	30±3,0	400,00
	6M 1500	1500	30±3,0	500,00
	6M 2100	2100	30±3,0	700,00
	6M 2700	2700	30±3,0	900,00
	6M 3300	3300	30±3,0	1100,00
9M	9M 1350	1350	30±3,0	450,00
	9M 1800	1800	30±3,0	600,00
	9M 2250	2250	30±3,0	750,00
	9M 3150	3150	30±3,0	1050,00
	9M 4050	4050	30±3,0	1350,00
	9M 4950	4950	30±3,0	1650,00

5M

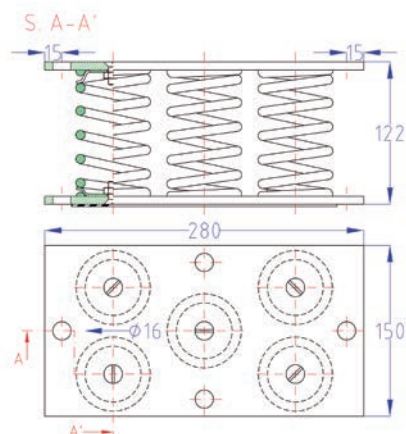

6M

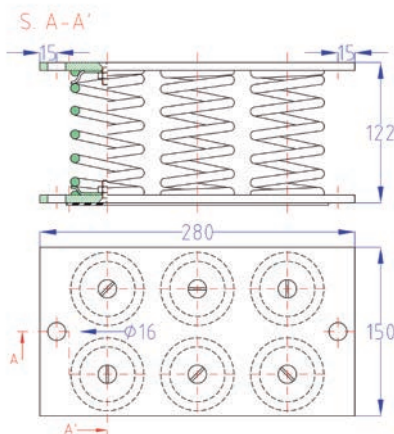

9M

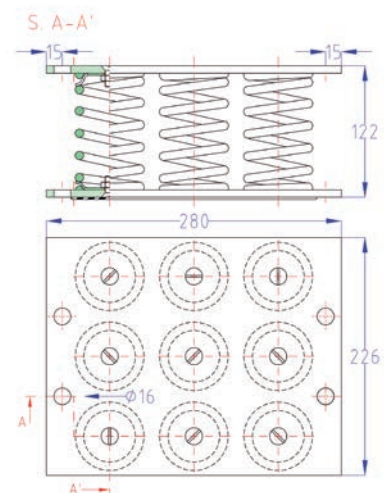

M / 2M / 3M / 4M (500 - 3000 kg.)

	REF / ART.NR	CARGA / LOAD CHARGE / LAST	FLECHA / DEFLECTION FLÈCHE / FEDERWEG	CONSTANTE / STIFFNESS RIGIDITE / STEIFIGKEIT
		kg.	mm.	kg./cm
M	M500	500	18±2,0	277,78
	M750	750	18±2,0	416,67
2M	2M 1000	1000	18±2,0	555,56
	2M 1500	1500	18±2,0	833,33
3M	3M 1500	1500	18±2,0	833,33
	3M 2250	2250	18±2,0	1.250,00
4M	4M 2000	2000	18±2,0	1.111,11
	4M 3000	3000	18±2,0	1.666,67

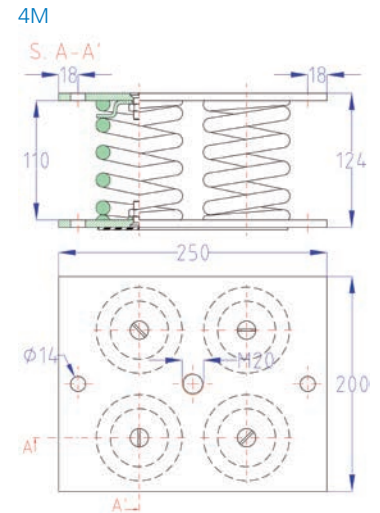
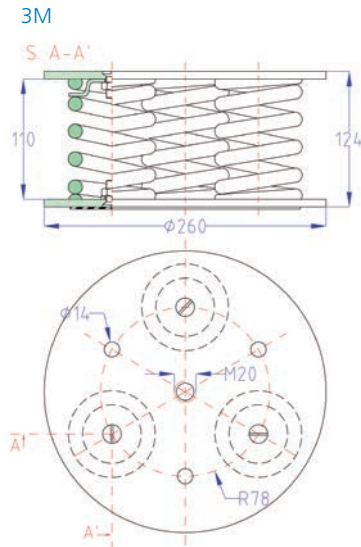
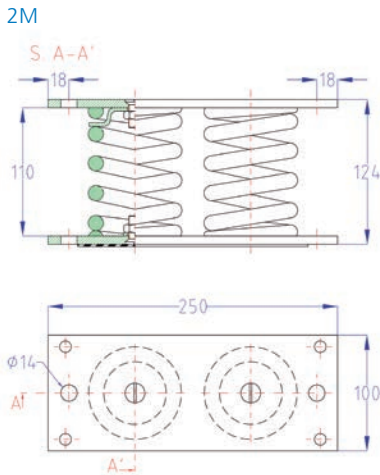
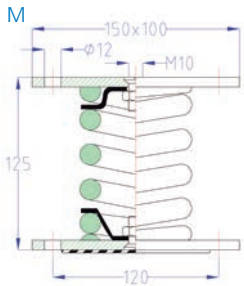

5M / 6M / 9M (2500 - 6750 kg.)

	REF / ART.NR	CARGA / LOAD	FLECHA / DEFLECTION	CONSTANTE / STIFFNESS
		CHARGE / LAST	FLÈCHE / FEDERWEG	RIGIDITE / STEIFIGKEIT
		kg.	mm.	kg./cm
5M	5M 2500	2500	18±2,0	1.388,89
	5M 3750	3750	18±2,0	2.083,33
6M	6M 3000	3000	18±2,0	1.666,67
	6M 4500	4500	18±2,0	2.500,00
9M	9M 4500	4500	18±2,0	2.500,00
	9M 6750	6750	18±2,0	3.750,00

5M

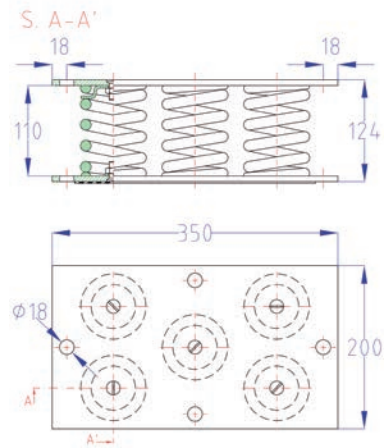

6M

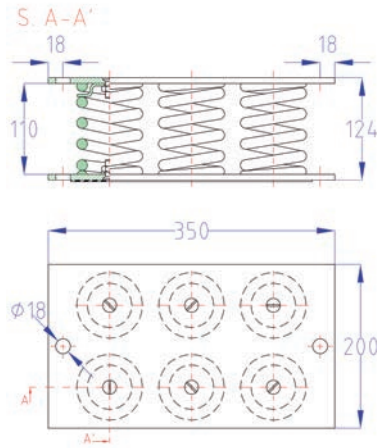

9M

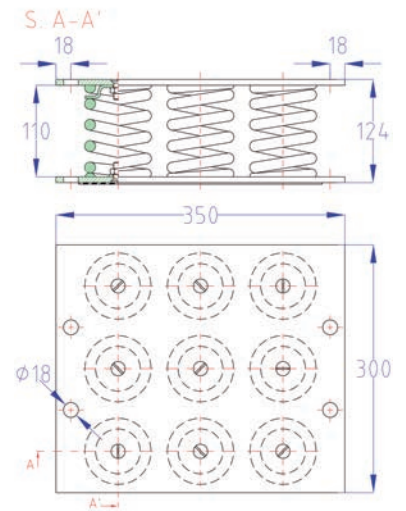

METÁLICOS / SPRINGS / RESSORTS / FEDERISOLATOREN 4 ASMN / 6 ASMN

	REF / ART.NR	CARGA / LOAD	FLECHA / DEFLECTION
		CHARGE / LAST	FLÈCHE / FEDERWEG
		kg.	mm.
4 ASMN	4 ASMN 600	600	30±3,0
	4 ASMN 700	700	30±3,0
	4 ASMN 800	800	30±3,0
	4 ASMN 900	900	30±3,0
	4 ASMN 1000	1000	30±3,0
	4 ASMN 1100	1100	30±3,0
	4 ASMN 1200	1200	30±3,0
	4 ASMN 1300	1300	30±3,0
	4 ASMN 1400	1400	30±3,0
	4 ASMN 1500	1500	30±3,0
	4 ASMN 1600	1600	30±3,0
	4 ASMN 1700	1700	30±3,0
	4 ASMN 1800	1800	30±3,0
	4 ASMN 1900	1900	30±3,0
	4 ASMN 2000	2000	30±3,0
	4 ASMN 2100	2100	30±3,0
	4 ASMN 2200	2200	30±3,0
	6 ASMN	6 ASMN 150	150
6 ASMN 175		175	20±2,0
6 ASMN 200		200	20±2,0
6 ASMN 225		225	20±2,0
6 ASMN 250		250	20±2,0
6 ASMN 275		275	20±2,0
6 ASMN 300		300	20±2,0
6 ASMN 325		325	20±2,0
6 ASMN 350		350	20±2,0
6 ASMN 375		375	20±2,0
6 ASMN 400		400	20±2,0
6 ASMN 425		425	20±2,0
6 ASMN 450		450	20±2,0
6 ASMN 475		475	20±2,0
6 ASMN 500		500	20±2,0
6 ASMN 550		550	20±2,0
6 ASMN 575		575	20±2,0
6 ASMN 600		600	20±2,0
6 ASMN 625		625	20±2,0
6 ASMN 650		650	20±2,0
6 ASMN 675	675	20±2,0	
6 ASMN 700	700	20±2,0	
6 ASMN 725	725	20±2,0	
6 ASMN 750	750	20±2,0	

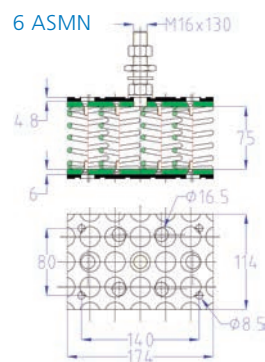
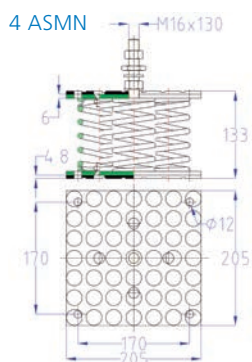

METÁLICOS / SPRINGS / RESSORTS / FEDERISOLATOREN HM / RM / HMB / HMBB

	REF / ART.NR	CARGA / LOAD CHARGE / LAST	FLECHA / DEFLECTION FLÈCHE / FEDERWEG	CONSTANTE / STIFFNESS RIGIDITE / STEIFIGKEIT
		kg.	mm.	kg./cm
HM	HM 05	5	7±1,0	7,14
	HM 10	10	7±1,0	14,29
	HM 20	20	7±1,0	28,57
	HM 30	30	7±1,0	42,86
	HM 40	40	7±1,0	57,14
	HM 50	50	7±1,0	71,43
RM	RM 05	5	7±1,0	7,14
	RM 10	10	7±1,0	14,29
	RM 20	20	7±1,0	28,57
	RM 30	30	7±1,0	42,86
	RM 40	40	7±1,0	57,14
	RM 50	50	7±1,0	71,43
HMB	HMB 05	5	7±1,0	7,14
	HMB 10	10	7±1,0	14,29
	HMB 20	20	7±1,0	28,57
	HMB 30	30	7±1,0	42,86
	HMB 40	40	7±1,0	57,14
	HMB 50	50	7±1,0	71,43
HMBB	HMBB 05	5	7±1,0	7,14
	HMBB 10	10	7±1,0	14,29
	HMBB 20	20	7±1,0	28,57
	HMBB 30	30	7±1,0	42,86
	HMBB 40	40	7±1,0	57,14
	HMBB 50	50	7±1,0	71,43

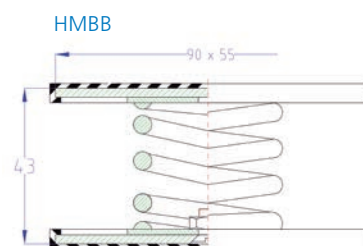
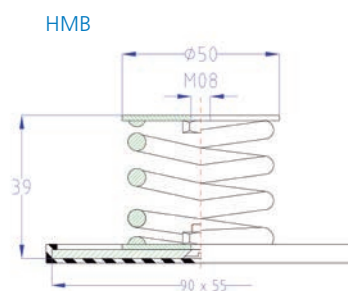
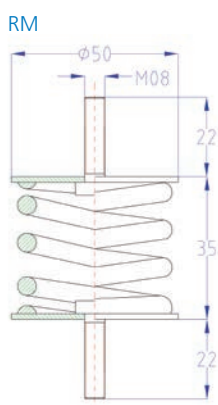
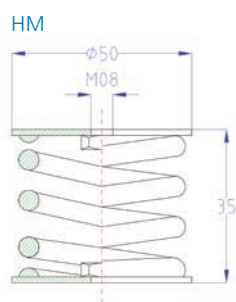

SUSTAINER TM / TV

	REF / ART.NR	DIMENSIONES / DIMENSIONS ABMESSUNGEN					COMPRESION / COMPRESSION DRUCKBELASTUNG		CONSTANTE / STIFFNESS RIGIDITE / STEIFIGKEIT	
		B	F	H	ØA	ØD	ØC	CARGA / LOAD CHARGE / LAST	FLECHA / DEFLECTION FLECHE / FEDERWEG	
	mm.					kg.	mm.	kg./cm		
TM	TM 25	75	55	100	12	30	11	25	24±3,0	10,42
	TM 50	75	55	100	12	30	11	50	24±3,0	20,83
	TM 75	75	55	100	12	30	11	75	24±3,0	31,25
	TM 100	75	55	100	12	30	11	100	24±3,0	41,67
	TM 125	75	55	100	12	30	11	125	24±3,0	52,08
	TM 150	120	75	155	16	30	14	150	35±4,0	42,86
	TM 200	120	75	155	16	30	14	200	35±4,0	57,14
	TM 250	120	75	155	16	30	14	250	35±4,0	71,43
	TM 350	120	75	155	16	30	14	350	35±4,0	100,00
	TM 450	120	75	155	16	30	14	450	35±4,0	128,57
TM 550	120	75	155	16	30	14	550	35±4,0	157,14	
TV	TV 10							10	30±3,0	3,33
	TV 20							20	20±2,0	10,00
	TV 30							30	20±2,0	15,00
	TV 40							40	20±2,0	20,00

Sustainer TM

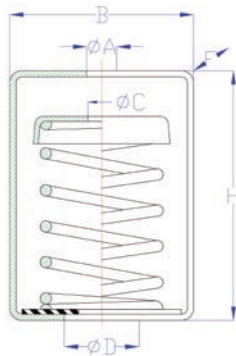

Sustainer TV

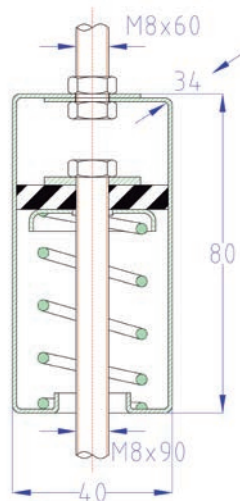

SUSTAINER TVAD-DS / TVA / TVAD10 / TVAR / TVAPL

TVAD

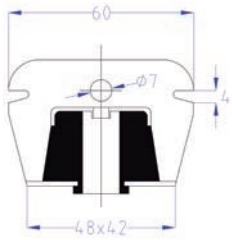

DS

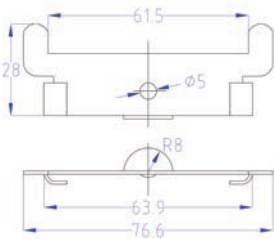

TVAD+DS

	REF / ART.NR	COMPRESSION / COMPRESSION DRUCKBELASTUNG			
		CARGA / LOAD CHARGE / LAST		FLECHA / DEFLECTION FLECHE / FEDERWEG	
		kg.		mm.	
TVA	TVA 40	8	25	1	3
	TVA 60	18	50	1	3
	TVA 75	25	75	1	3
TVAD10	TVA40 D10	8	25	1	3
	TVA60 D10	18	50	1	3
	TVA75 D10	25	75	1	3
TVAR	TVAR 40	8	25	1	3
	TVAR 60	18	50	1	3
	TVAR 75	25	75	1	3
TVAPL	TVAPL 40	8	25	1	3
	TVAPL 60	18	50	1	3
	TVAPL 75	25	75	1	3
TVAD	TVAD 40	8	25	1	3
	TVAD 60	18	50	1	3
	TVAD 75	25	75	1	3
	DS				

TVA

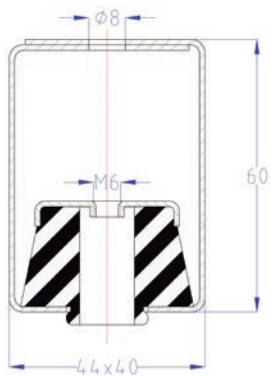

TVAD10

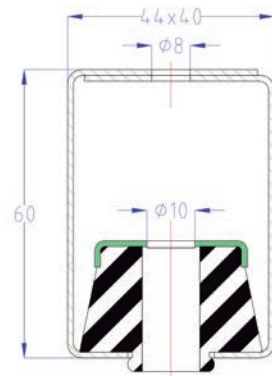

TVAR

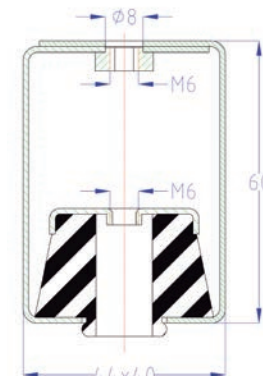

TVAPL

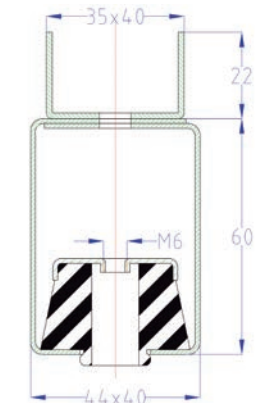

SUSTAINER TPA / TPB

REF / ART.NR
TPA 16

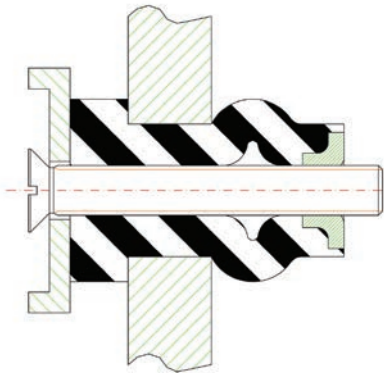
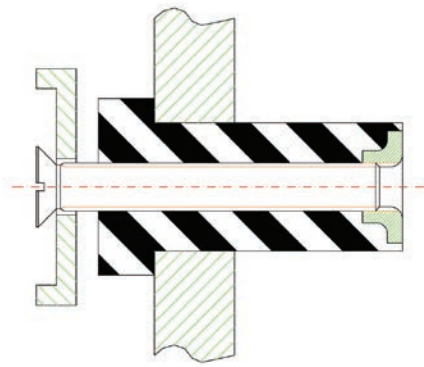
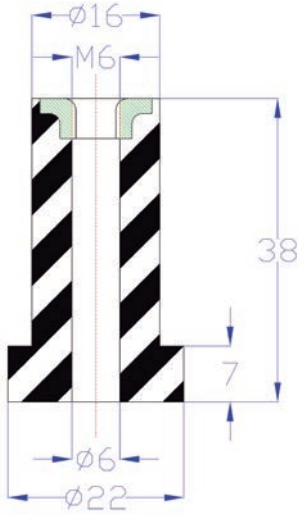

TPA

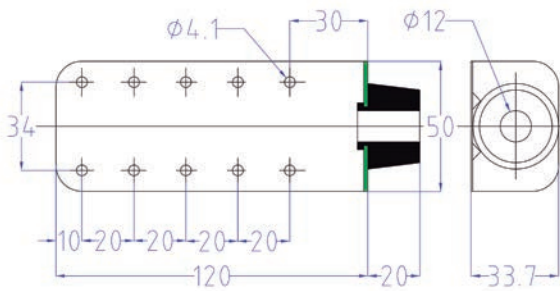

TPB



REF / ART.NR
TPB

M800 / M800 INOX / M700

	REF / ART.NR	DIMENSIONES / DIMENSIONS ABMESSUNGEN					COMPRESION / COMPRESSION DRUCKBELASTUNG
		Sh	Ø A	B	D	C	CARGA / LOAD CHARGE / LAST
		mm.					kg.
M-800	M-800	75	45	20	M-8	100	0-100
	M-800	75	45	20	M-10	77	0-100
	M-801	75	75	25	M-12	120	100-200
	M-802	75	98	30	M-12	120	200-400
	M-802	75	98	30	M-16	170	200-400
	M-803	75	125	30	M-16	170	400-700
	M-804	75	175	37	M-16	170	700-1500
	M-805	75	222	42	M-20	200	1500-3000
	M-806	75	222	61	M-24	215	3000-5000
*fabricado con caucho BUTILO (IDEALE) y NITRILO (SINTÉTICO) / made in rubber butyl (IDEALE) and nitrile (SYNTHETIC) / fabriqué en caoutchouc butyle (IDEALE) et nitrile (SYNTHETIQUE) / Hergestellt aus Nitril-Kautschuk und aus Butadien-Kautschuk							
M-800 INOX	M-800-X	75	45	20	M-8	100	0-100
	M-801-X	75	75	25	M-12	120	100-200
	M-802-X	75	98	30	M-12	120	200-400
	M-803-X	75	125	30	M-16	170	400-700
	M-804-X	75	175	37	M-16	170	700-1500
*fabricado con NITRILO (SINTÉTICO) / made in nitrile (SYNTHETIC) / fabriqué en nitrile (SYNTHETIQUE) / Hergestellt aus Nitril-Kautschuk							
M-700	M-700	65	45	20	M-8	100	0-100
	M-700	65	45	20	M-10	78	0-100
	M-701	65	75	24	M-12	120	100-250
	M-702	65	98	29	M-12	120	250-400
	M-703	65	124	30	M-16	170	400-700
	M-704	65	175	36	M-16	170	700-1500
	M-705	65	222	42	M-20	200	1500-2500
	M-706	65	222	61	M-24	215	2500-3800
*fabricado en CAUCHO NATURAL(NR) / made in natural rubber (NR) / fabriqué en caoutchouc naturel (NR) / Hergestellt aus Natur-Kautschuk							

M-800

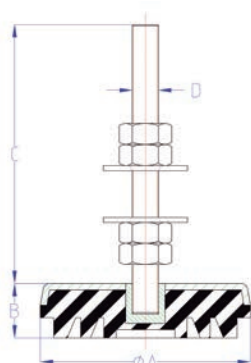

M-800 INOX

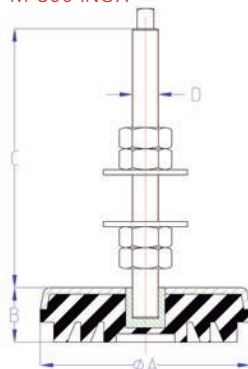

M-700

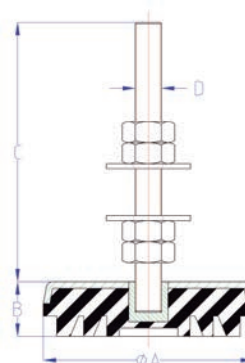

M600 (RÓTULA / ARTICULATED / ARTICULÉ / GELENKFUß)

REF / ART.NR	DIMENSIONES / DIMENSIONS ABMESSUNGEN					COMPRESION / COMPRESSION DRUCKBELASTUNG
	Sh	Ø A	B	D	C	CARGA / LOAD CHARGE / LAST
			mm.			kg.
M-600	75	48	20	M-10	70	0-60
M-601	75	75	28	M-12	100	60-125
M-602	75	100	28	M-12	100	125-200
M-603	75	128	30	M-16	160	200-400
M-604	75	180	36	M-16	160	400-700
M-607	75	180	44	M-16	160	700-1400
M-605	75	226	47	M-20	185	1400-2000
M-606	75	226	60	M-20	185	2000-3000
M-608	75	226	78	M-24	215	3000-5000

*fabricado con NITRILO (SINTÉTICO) y BUTILO (IDEALE) / made in nitrile (SYNTHETIC) and butyl (IDEALE) / fabriqué en nitrile (SYNTHETIQUE) et butyle (IDEALE) / Hergestellt aus Nitril-Kautschuk und aus Butadien-Kautschuk

*Toda la serie M-600 se fabrica con plancha metálica intermedia reforzante / The whole M-600 range is made with a reinforcing metal plate in the middle / Toute la série M-600 est fabriquée avec une planche métallique intermédiaire de renfort / Die gesamte M-600 Serie ist mit einer zwischenliegenden Metallscheibe verstärkt

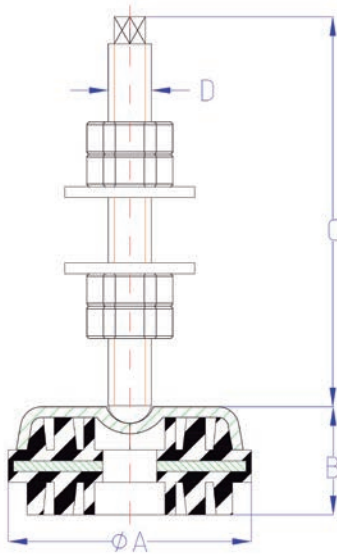

M-600



M-600L



M-600I

Máximo desnivel permitido de la base 8%
Maximum allowed slope on the base 8%
Inclination maximale acceptée de la base 8%
Erlaubte Bodenschräge max 8%

M600 R / M600 T

M-600 R	REF / ART.NR		DIMENSIONES / DIMENSIONS ABMESSUNGEN				COMPRESION / COMPRESSION DRUCKBELASTUNG
	Sh	Ø A	B	D	C	CARGA / LOAD CHARGE / LAST	
	mm.					kg.	
	M-604 R	75	180	56	M-16	160	100-700
	M-607-R	75	180	62	M-16	160	700-1400
	M-605-R	75	226	70	M-20	185	1400-2000
	M-606-R	75	226	77	M-20	185	2000-3000
*fabricado con NITRILO (SINTÉTICO) y BUTILO (IDEALE) / made in nitrile (SYNTHETIC) and butyl (IDEALE) / fabriqué en nitrile (SYNTHETIQUE) et butyle (IDEALE) / Hergestellt aus Nitril-Kautschuk und aus Butadien-Kautschuk							
M-600 T	REF / ART.NR		DIMENSIONES / DIMENSIONS ABMESSUNGEN			COMPRESION / COMPRESSION DRUCKBELASTUNG	
	Sh	Ø A	Ref./ART.NR2	D	Ref./ART.NR1	CARGA / LOAD CHARGE / LAST	
	mm.					kg.	
	T-1	75	12	M-601 T	M8 / M10	M-600 T	0-100
	T-2	75	15	M-602 T	M-12	M-601 T	100-200
	T-3	75	15	M-603 T	M-12	M-601 T	200-400
	T-4	75	24	M-604 T	M16 / M20	M-602 T	400-700
	T-5	75	24	M-607 T	M-16	M-602 T	700-1200
	T-6	75	24	M-605 T	M-20	M-603 T	1200-1800
	T-7	75	24	M-606 T	M-20	M-603 T	1800-2500
*fabricado con NITRILO (SINTÉTICO) y BUTILO (IDEALE) / made in nitrile (SYNTHETIC) and butyl (IDEALE) / fabriqué en nitrile (SYNTHETIQUE) et butyle (IDEALE) / Hergestellt aus Nitril-Kautschuk und aus Butadien-Kautschuk							

M-600 R

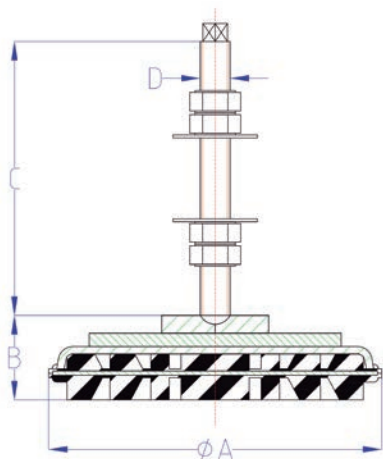

M-600 T

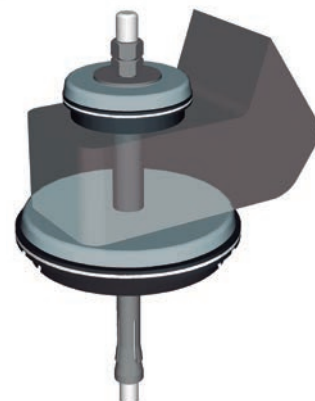
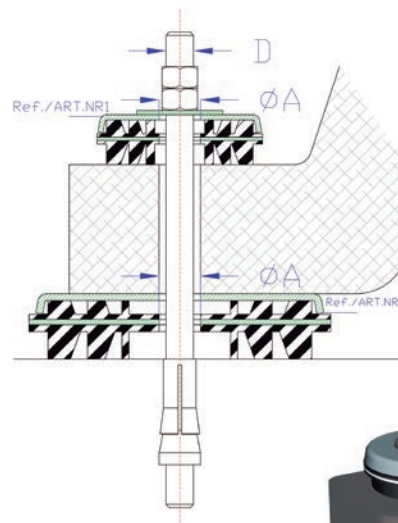

M940 / M950 / M

M-940	REF / ART.NR		DIMENSIONES / DIMENSIONS ABMESSUNGEN			COMPRESION / COMPRESSION DRUCKBELASTUNG	
	Sh	Ø A	Ø B	C	CARGA / LOAD CHARGE / LAST		
	mm.				kg.		
	M-942	75	59	29	27	0-75	
	M-944	75	70	40	28	75-90	
	M-946	75	80	49	33	90-120	
	M-948	75	87	60	35	120-150	
*Fabricado con BUTILO (IDEALE) / made in butyl (IDEALE) / fabriqué en butyle (IDEALE) / Hergestellt aus Butadien-Kautschuk							
M-950	REF / ART.NR		DIMENSIONES / DIMENSIONS ABMESSUNGEN			COMPRESION / COMPRESSION DRUCKBELASTUNG	
	Sh	Ø A	B	M	C	CARGA / LOAD CHARGE / LAST	
	mm.				kg.		
	M-952	75	59	25	M-8	100	0-75
	M-952	75	59	25	M-10	77	0-75
	M-954	75	70	31	M-12	120	75-90
	M-956	75	80	33	M-12	120	90-120
*Fabricado con BUTILO (IDEALE) / made in butyl (IDEALE) / fabriqué en butyle (IDEALE) / Hergestellt aus Butadien-Kautschuk							
M	REF / ART.NR		DIMENSIONES / DIMENSIONS ABMESSUNGEN			COMPRESION / COMPRESSION DRUCKBELASTUNG	
	Sh	A	B	C	CARGA / LOAD CHARGE / LAST		
	mm.				kg.		
	M-963	75	35	35	15	0-20	
	M-1060	75	50	50	22	20-40	
	M-1062	75	53	65	28	40-60	
	M-965	75	44		11	0-20	
*Fabricado con BUTILO (IDEALE) / made in butyl (IDEALE) / fabriqué en butyle (IDEALE) / Hergestellt aus Butadien-Kautschuk							

M-940

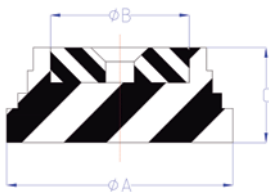

M-950

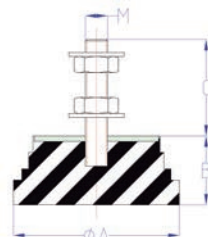

M

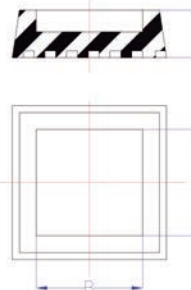

M-965

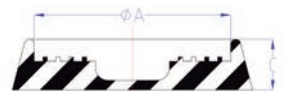

M910 / M915/921

M-910	REF / ART.NR		DIMENSIONES / DIMENSIONS ABMESSUNGEN			COMPRESION / COMPRESSION DRUCKBELASTUNG
	Sh	A	B	C	CARGA / LOAD CHARGE / LAST	
	mm.				kg.	
	M-911	75	122	67	18	0-150
	M-912	75	204	83	18	150-300
	M-913	75	225	115	18	300-500
	M-914	75	256	155	18	500-700
	M-922	75	125	67	35	0-250
	M-924	75	204	85	35	250-500
	M-925	75	150	130	35	500-700
	M-926	75	223	115	35	600-700
	M-929	75	256	152	35	750-1000

**fabricado con caucho BUTILO (IDEALE) / made in rubber butyl (IDEALE) / fabriqué en caoutchouc butyle (IDEALE) / Hergestellt aus Butadien-Kautschuk*

M-915/921	REF / ART.NR		DIMENSIONES / DIMENSIONS ABMESSUNGEN				COMPRESION / COMPRESSION DRUCKBELASTUNG
	Sh	A	B	C	D	CARGA / LOAD CHARGE / LAST	
	mm.					kg.	
	M-915	75	230	140	30	19	0-600
	M-917	75	230	140	30	19	0-600
	M-920	75	210	125	26	13	0-400
	M-921	75	210	125	26	13	0-400

**fabricado con caucho BUTILO (IDEALE) / made in rubber butyl (IDEALE) / fabriqué en caoutchouc butyle (IDEALE) / Hergestellt aus Butadien-Kautschuk*

M-910

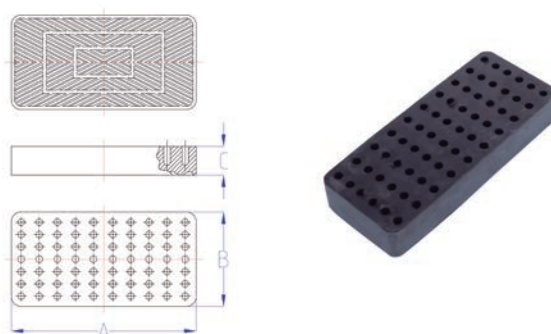

M-915D / M-921D

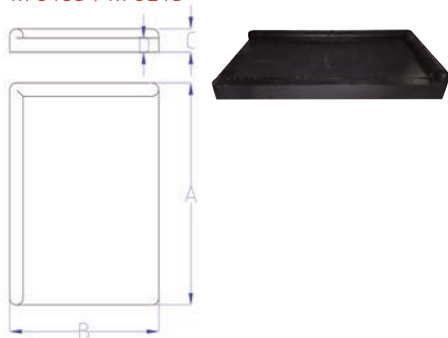

M-915I / M-921I

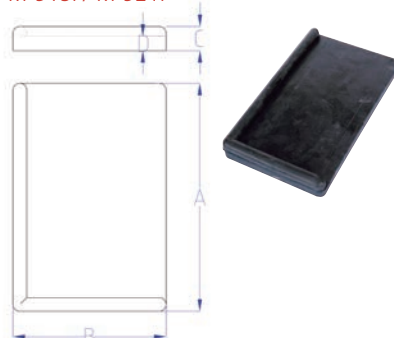

M-917 / M-920



M980 / M970

M-980	REF / ART.NR		DIMENSIONES / DIMENSIONS ABMESSUNGEN				COMPRESION / COMPRESSION DRUCKBELASTUNG			
		Sh	A	B	C					
			mm.				kg.			
	M-980	75	470	117	17		0-300			
	M-981	75	470	117	25		300-450			
	M-983	75	470	470	17		450-1500			
	M-985	75	470	470	25		1500-2000			
*fabricado con caucho BUTILO (IDEALE) / made in rubber butyl (IDEALE) / fabriqué en caoutchouc butyle (IDEALE) / Hergestellt aus Butadien-Kautschuk										
M-970	REF / ART.NR		DIMENSIONES / DIMENSIONS ABMESSUNGEN						COMPRESION / COMPRESSION DRUCKBELASTUNG	
		Sh	A	B	C	M	L	F	Ø J	
			mm.							kg.
	M-970	75	33	35	42	M-8	42	76	8	0-100
	M-972	75	75	40	95	M-12	118	121	10	0-400
	M-975	75	117	60	110	M-16	150	184	14	400-1250
	M-978	75	140	100	135	M-16	215	246	16	1250-2000
*fabricado con caucho BUTILO (IDEALE) / made in rubber butyl (IDEALE) / fabriqué en caoutchouc butyle (IDEALE) / Hergestellt aus Butadien-Kautschuk										

M-980

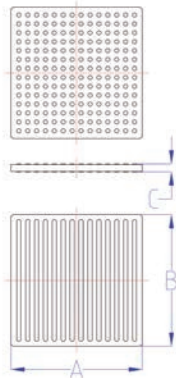

M-970

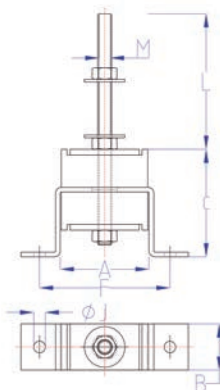

M400

M-400 CS	REF / ART.NR		DIMENSIONES / DIMENSIONS ABMESSUNGEN						COMPRESION / COMPRESSION DRUCKBELASTUNG		
	Sh	Ø A	B	Ø C	D	Ø E	F	G	CARGA / LOAD CHARGE / LAST		
	mm.									kg.	
	M-410	60	46	23	8	68	6,5	81	2	45-90	
	M-412	60	60	31	10	85	8,5	106	3	100-200	
	M-414	60	92	45	16	110	10,5	128	3	200-400	
	M-416	60	108	50	24	160	16,5	190	5	400-600	
<p><i>*fabricado con NITRILO (SINTÉTICO) / made in rubber nitrile (SYNTHETIC) / fabriqué en caoutchouc nitrile (SYNTHETIQUE) / Hergestellt aus Nitril-Kautschuk</i></p> <p><i>*CS agujero libre / CS plain hole / CS trou lisse / CS glattes Loch</i></p>											
M-400 CF	REF / ART.NR		DIMENSIONES / DIMENSIONS ABMESSUNGEN						COMPRESION / COMPRESSION DRUCKBELASTUNG		
	Sh	Ø A	B	C	D	Ø E	F	G	CARGA / LOAD CHARGE / LAST		
	mm.									kg.	
	M-420	60	48	23	M-8	68	6,5	81	2	45-90	
	M-422	60	60	31	M-10	85	8,5	106	3	100-200	
	M-424	60	92	45	M-14	110	10,5	128	3	200-400	
	M-426	60	108	50	M-16	160	16,5	190	5	400-600	
<p><i>*fabricado con NITRILO (SINTÉTICO) / made in rubber nitrile (SYNTHETIC) / fabriqué en caoutchouc nitrile (SYNTHETIQUE) / Hergestellt aus Nitril-Kautschuk</i></p> <p><i>*CF agujero rosca / CF screwed hole / CF trou taraudé / CF Innengewinde</i></p>											

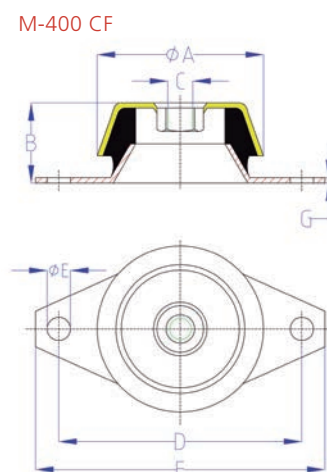
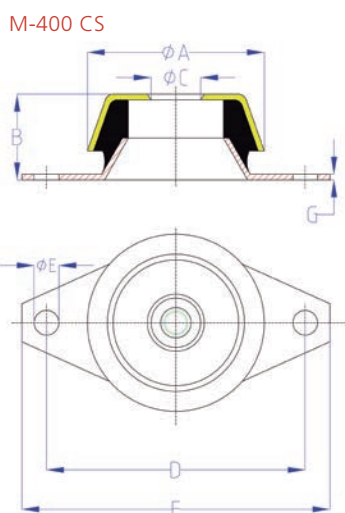

1000 DISCOBOLO

1000	REF / ART.NR	SERIES				DIMENSIONES / DIMENSIONS / ABMESSUNGEN			COMPRESION / COMPRESSION / DRUCKBELASTUNG	COMPRESION / COMPRESSION / DRUCKBELASTUNG
		EE	TT	TE	E	Ø A	B	M x L	CARGA / LOAD CHARGE / LAST	CARGA / LOAD CHARGE / LAST
						mm.			65SH	75SH
	M-1003	x			x	25	25	M-4X14	0-20	0-30
	M-1006	x			x	35	30	M-5X14	20-60	30-90
	M-1009	x	x	x	x	45	35	M-8X23	60-80	90-120
	M-1012	x	x	x	x	55	44	M-8X22	80-120	120-170
	M-1014	x	x	x	x	60	60	M-10X26	100-130	140-190
	M-1015	x	x	x	x	69	50	M-10X26	120-175	170-250
	M-1018		x			85	60	M-12	175-260	250-375
	M-1020		x			97	54	M-14	210-420	300-600
	M-1021		x			97	59	M-14	240-490	350-700
	M-1029		x			125	65	M-16	490-1050	700-1500
	M-1032		x			175	81	M-16	850-1300	1200-1800
	M-1035		x			225	90	M-24	1300-1800	1500-2200

*fabricado en CAUCHO NATURAL (NR) / made in natural rubber (NR) / fabriqué en caoutchouc naturel (NR) / Hergestellt aus Natur-Kautschuk

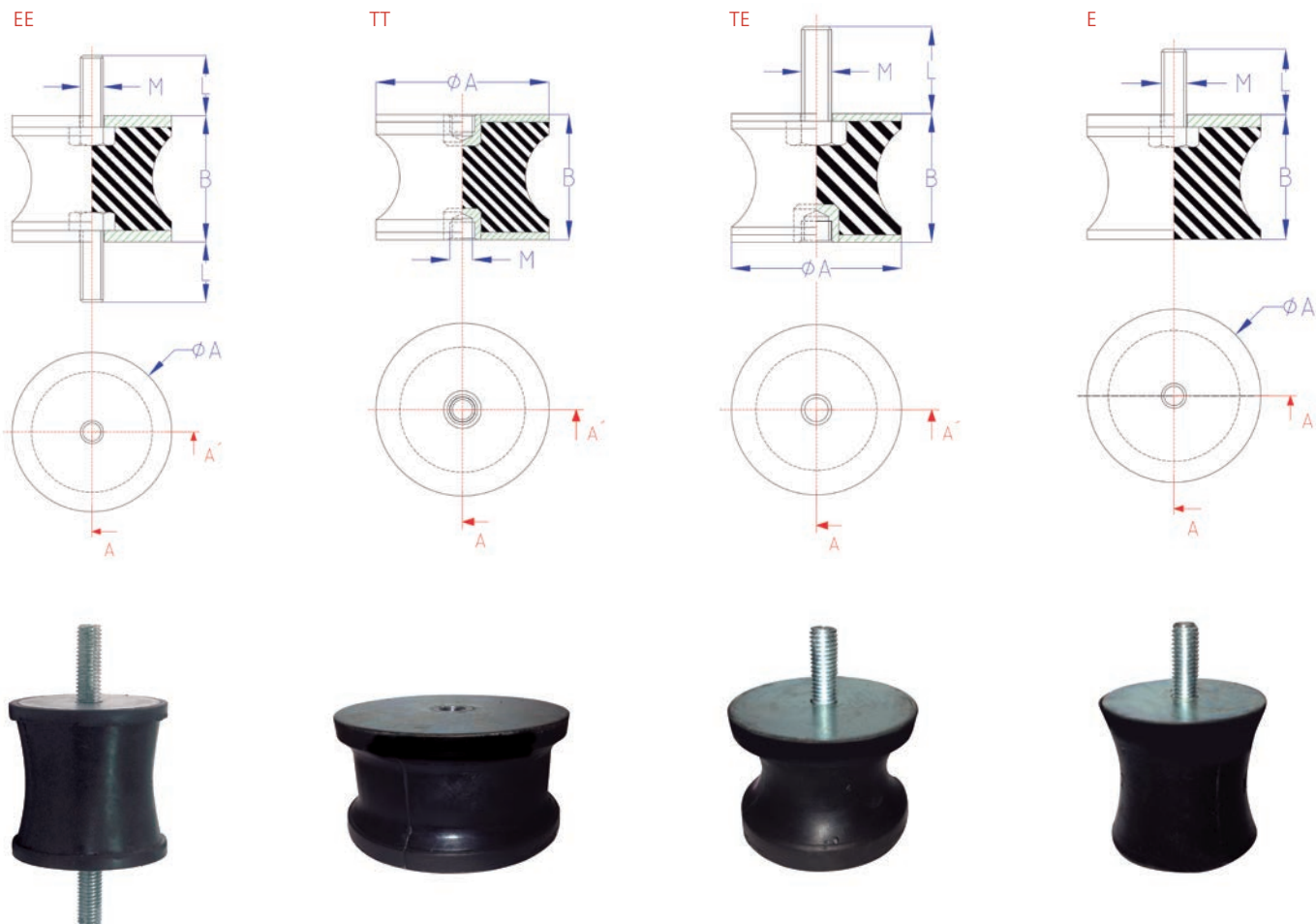

STABREN

STABREN	REF / ART.NR		DIMENSIONES / DIMENSIONS ABMESSUNGEN		COMPRESION / COMPRESSION DRUCKBELASTUNG	
	Sh	Sh	cm ²	Tm x un	CARGA / LOAD CHARGE / LAST	
	kg.					
	35-25-35	35	35	0,1-2,5 kg	1	40-1000
	35-25-45	35	45	2,5-3,5 kg	1,5	1000-1500
	45-25-45	45	45	3,5-9,5 kg	3,8	1500-3800
	45-25-65	45	65	9,5-12 kg	4,8	3800-4800
	65-25-65	65	65	12-15 kg	6	4800-6000
	65-25-85	65	85	15-18 kg	7,2	6000-7200
	85-25-85	85	85	18/+	10	7200-10000

**fabricado con caucho BUTILO (IDEALE) / made in rubber butyl (IDEALE) / fabriqué en caoutchouc butyle (IDEALE) / Hergestellt aus Butadien-Kautschuk*

Dimensiones: largo: 200mm / ancho:200mm / alto: 25mm

Dimensions: length:200mm / width: 200mm / height: 25mm

Dimensions: longueur: 200mm / largeur: 200mm / hauteur: 25mm

Dimensionen: Länge: 200mm / Breite: 200mm/ Höhe: 200mm



TP-M

TP-M	REF / ART.NR		DIMENSIONES / DIMENSIONS / ABMESSUNGEN				RIGIDEZ / STIFFNESS RIGIDITE / STEIFIGKEIT	FLECHA / DEFLECTION FLECHE / FEDERWEG
		Sh	D	H	Ø M	L	CARGA / LOAD CHARGE / LAST	CARGA / LOAD CHARGE / LAST
	mm.						daN/mm.	mm.
	M-2425 M618	50	24	25	M-6	18	3	5,5
	M-2435 M618	50	24	35	M-6	18	3,5	7
	M-3030 M614	50	30	30	M-6	14	4,9	6
	M-3036 M614	50	30	36	M-6	14	5,5	7,2
	M-4530 M823	50	45	30	M-8	23	12,8	6
	M-5050 M823	50	50	50	M-8	23	5,7	10
	M-5050 M1025	50	50	50	M-10	25	5,7	10
	M-5067 M833	50	50	67	M-8	33	4,9	13,4
	M-6060 M1237	50	60	60	M-12	37	13	12

**fabricado en CAUCHO NATURAL (NR) / made in natural rubber (NR) / fabriqué en caoutchouc naturel (NR) / Hergestellt aus Natur-Kautschuk*

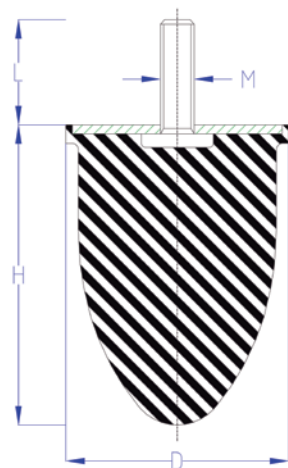

1100

REF / ART.NR	SERIES					DIMENSIONES / DIMENSIONS / ABMESSUNGEN			COMPRESSION / COMPRESSION / DRUCKBELASTUNG
	Sh	EE	TT	TE	E	Ø A	B	M x L	CARGA / LOAD CHARGE / LAST
							mm.		
M-1100	50	X	X			15	15	M-4X13	8-10
M-1106		X	X	X	X		15	M-6X18	50-60
M-1108	50	X	X	X	X	20	20	M-6X18	30-40
M-1110		X	X	X	X		25	M-6X18	25-30
M-1116		X					15	M-6X18	65-70
M-1118	50	X	X			25	20	M-6X18	48-65
M-1120		X	X	X	X		25	M-6X18	30-35
M-1122		X	X	X	X		30	M-6X18	25-30
M-1128		X		X	X		15	M-8X20	85-95
M-1130		X	X	X	X		20	M-8X20	55-65
M-1132	50	X		X	X	30	25	M-8X20	45-55
M-1134		X	X	X	X		30	M-8X20	35-45
M-1136		X	X	X			40	M-8X20	30-35
M-1140		X					20	M-8X23	170-220
M-1142	50	X	X	X	X	40	30	M-8X23	140-170
M-1144		X	X		X		35	M-8X28	85-95
M-1146	50	X		X	X	40	40	M-10X25 M-10X28	70-80
M-1150		X					20	M-10X25	290-330
M-1152		X	X		X		30	M-10X25	200-260
M-1154	50	X	X	X	X	50	35	M-10X25	170-200
M-1156		X	X				40	M-10X33	150-170
M-1158		X	X	X	X		45	M-10X33	125-150
M-1164	50	X			X	60	30	M-10X25 M-12X37	300-350
M-1166		X	X				40	M-10X24	210-240
M-1168	50	X	X		X	60	50	M-12X37	170-210
M-1172	50	X	X	X	X	75	40	M-12X37	400-500
M-1180	50	X	X			100	40	M-16X44	800-900
M-1182	50	X		X		100	75	M-16X41 M-16X44 M-16	600-700

*fabricado en CAUCHO NATURAL (NR) / made in natural rubber (NR) / fabriqué en caoutchouc naturel (NR) / Hergestellt aus Natur-Kautschuk

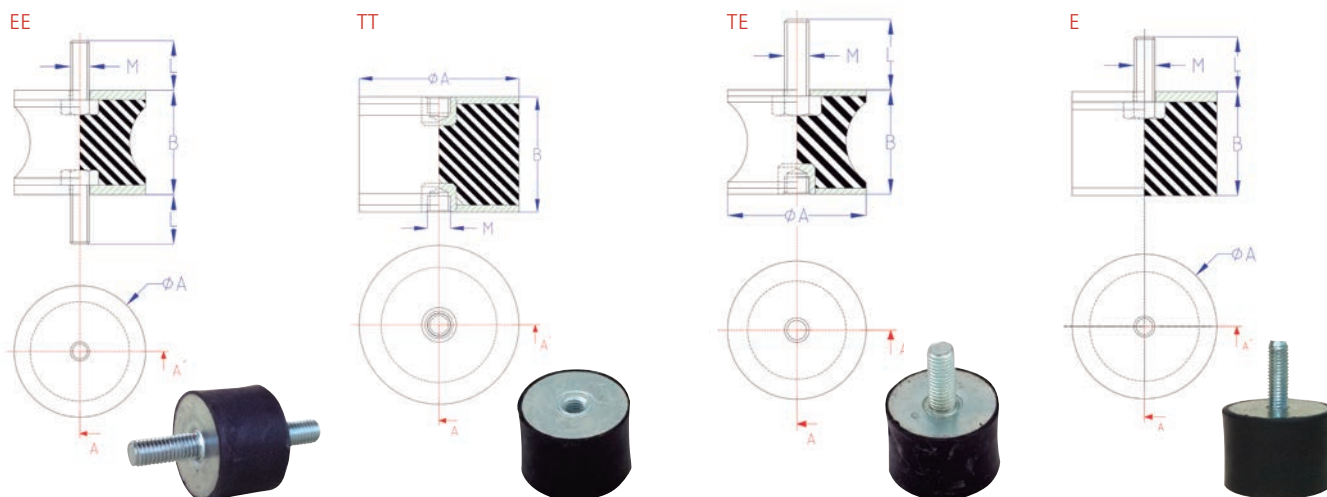



www.lesol.es

Pol. Industrial Lastaola
Parcela 3
Naves A8-A11
20120 Hernani (Guipúzcoa)
Tel: +34 943 335 350
Fax: +34 943 335 291
Email: comercial@lesol.es